

**MECHANICAL
BOOSTER PUMPS**

300 - 30000

FOR INDUSTRIAL

VACUUM

PROCESSES

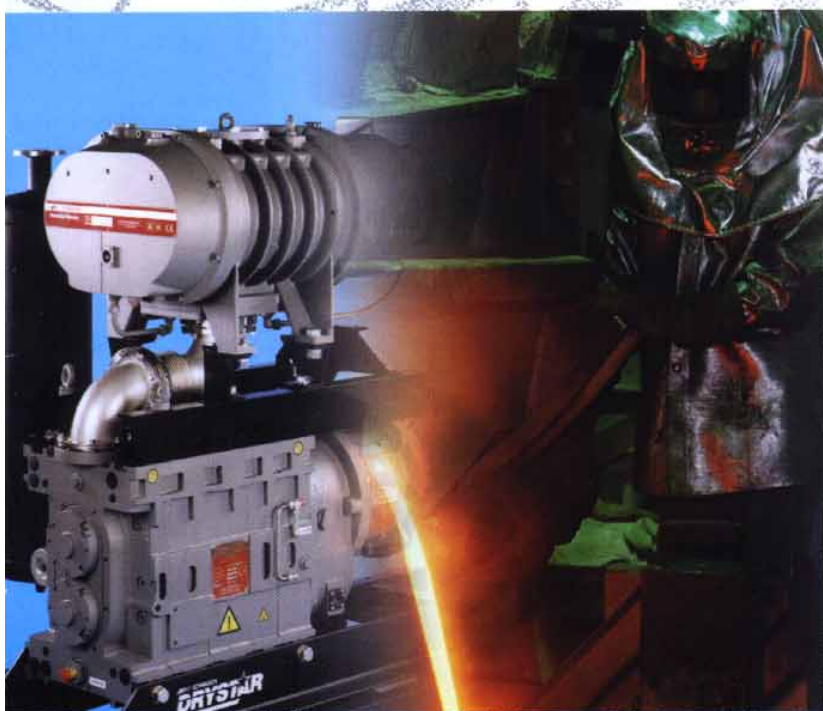



LARGEST RANGE

With over 100,000 pumps in the field, BOC Edwards is recognised as a leading supplier of vacuum mechanical boosters to the industrial market. Every day BOC Edwards boosters are used in different applications from metallurgy, semiconductor, packaging, thin film deposition to high energy physics Edwards makes four different ranges of pumps allowing every vacuum user to find a system which suits exactly his needs.



QMB250 and EH1200

EH SERIES

The EH blowers cover the range from 300 to 4,200 m³/h and offer a unique and patented design using the hydrokinetic drive which has the following benefits:

- ⇒ Reduced pumpdown time up to 50%
- ⇒ Reduced capital and operating cost
- + Simple and economic installation: no pressure sensors, by-pass lines or valves; compact design
- ⇒ Quiet, vibration free operation
- ⇒ Can operate continuously at all pressures

HV SERIES

Direct drive, high speed blowers from 1,000 to 30,000 m³/h featuring:

- ⇒ Vertical or horizontal flow
- ⇒ After coolers as standard
- ⇒ Water cooled bearings and seals
- ⇒ Nitrogen purge
- ⇒ Thermal protection device
- ⇒ Inverter drive option



HV30000

QMB SERIES

QMB blowers feature pumping speeds from 300 to 1,200 m³/h.

More specifically designed for applications involving corrosive gases, these blowers have PFPE fluid. They are also well adapted to operation in a clean environment such as clean rooms, being fitted with water cooled motors.

EDD SERIES

Direct drive blowers with pumping speeds from 1,200 to 4,200 m³/h. These blowers are suited for applications where it is needed to keep a constant pressure differential between inlet and exhaust such as lasers.

Special versions have nickel plated rotors for high corrosion resistance.

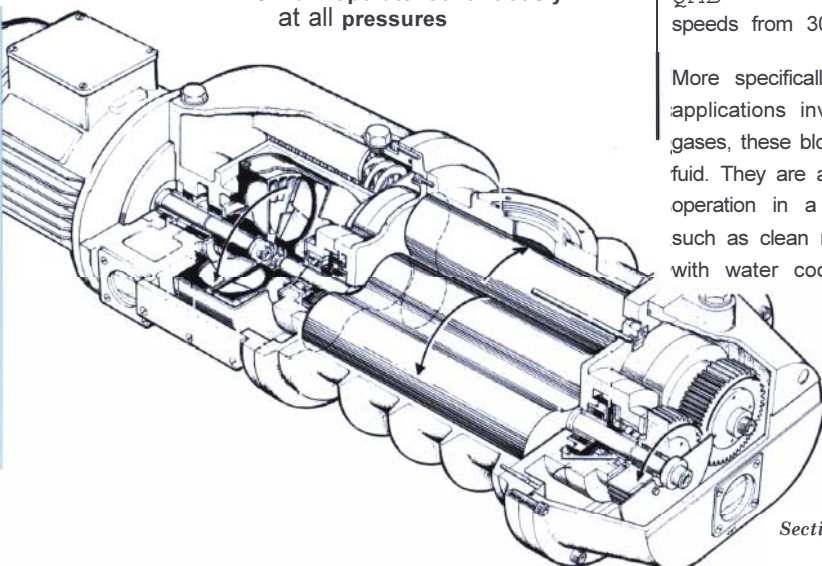

Section view of EHpump



Operation of Booster pumps

The mechanical booster operates on the Roots principle. It is made of two rotors rotating in opposite directions in a stator. Due to the lobe shape of the rotors and to the synchronisation their rotation through a pair of gears, these rotors remain permanently tangent to each other and tangent to the stator. During the rotation, a volume of gas is trapped between each rotor and the wall of the stator and transferred without internal compression from the inlet side to the outlet side.

This operation mode gives to the Roots blower some specific characteristics which are particularly valuable in industrial applications. It also determines the conditions in which a roots pump can be used in vacuum technology.

Specific advantages of mechanical boosters for industrial applications

⇒ Clean and dry pumping

By nature, the roots is a dry pump. As there is no fluid in the swept volume, the pumped gas has no contact with oil or water. This gives a clean pumping and reduces corrosion.

⇒ Reliable operation

Due to the absence of fluid and to relatively large clearances, the mechanical booster can tolerate condensable vapours and fine dust which will go through it without accumulating inside the pump or in the pumping fluid. This is particularly effective when the machine is mounted with vertical gas flow.

⇒ High pumping efficiency

The mechanical booster is a compact machine able to transfer large gas flows in an intermediate pressure range from 10 to 10^{-3} mbar where the pumping speed of oil sealed rotary pumps decreases.

Limitations of mechanical blowers

⇒ Exhausting to atmospheric pressure

They are unsuitable to exhaust on their own above 500 mbar and must always be backed by another pump capable of delivering gases against high pressure differentials to atmosphere. As such the mechanical booster will act as a pumping "accelerator" improving substantially the pumping speed and the vacuum performance of the backing pump.

⇒ Operation from atmosphere

There are limitations to the pressure and the compression ratio that can be tolerated by a booster. When roughing a vacuum system, the initial pressure difference is too high for the booster to operate, so a direct drive booster must remain switched off until the forepump has reduced the pressure to a suitable level

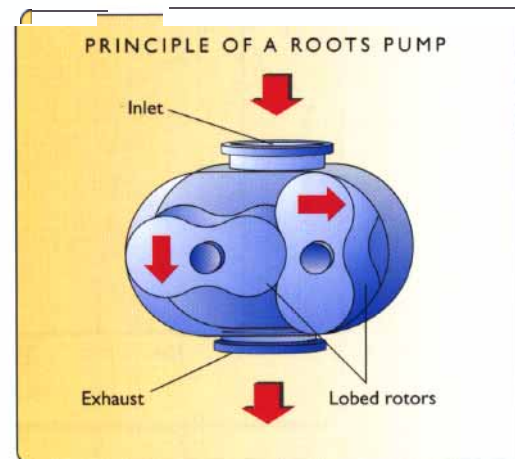



THE RIGHT SOLUTION

Edwards developed and patented the hydrokinetic drive which allows continuous running at all pressures and prevents motor overload in the EH and QMB series. The hydrokinetic fluid coupling is integral with the pump and enables both pumps to be started at atmospheric pressure. This configuration has the following benefits

- ⇒ No need for bypass lines, valves, pressure switches
- ⇒ Starts from atmosphere without overload, protects motor without the need for inverters
- ⇒ Simple installation, can be mounted directly on to backing pump.
- ⇒ Improved pump down-time

When started simultaneously with the backing pump from atmosphere, it helps to accelerate the pump down as shown below. The curves compare the evacuation time of a chamber, obtained by a conventional method in which the booster is delayed until a predetermined pressure is reached below which the motor is not overloaded. In the event of accidental air inrush the pump is self-protecting.

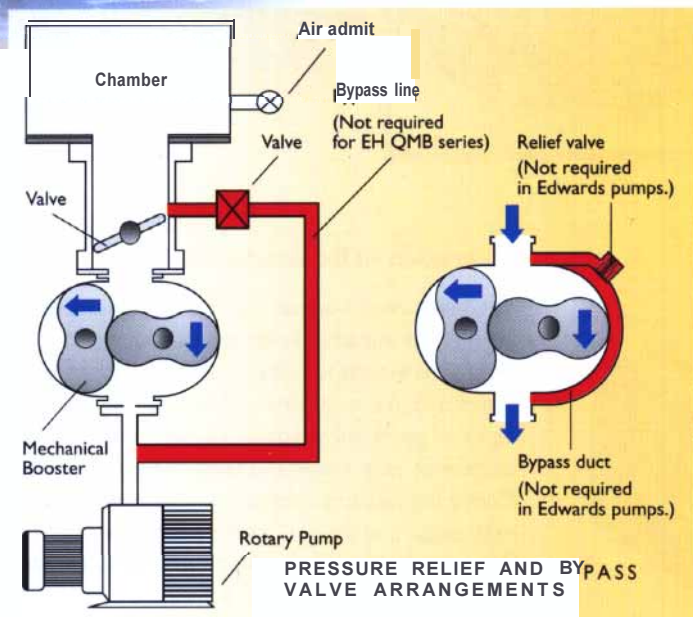
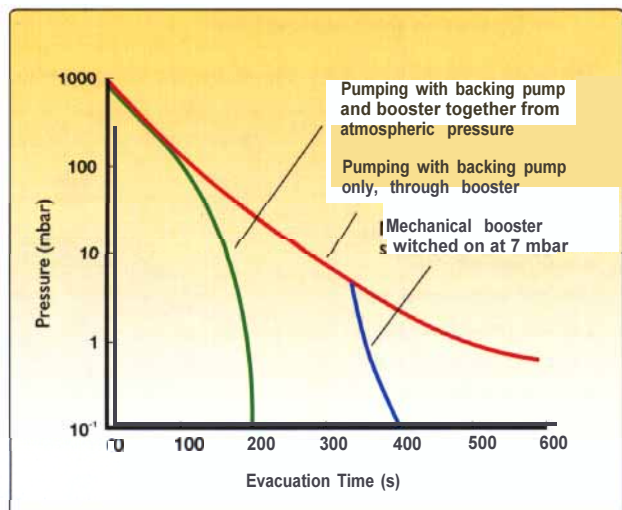

Some manufacturers overcome the problem of motor overloading using a bypass around the booster incorporating a valve which opens or closes according to the pressure difference allowing the gas to circulate. This solution can limit high pressure pumping and can cause overheating.

Other manufacturers incorporate a pressure relief valve in the pump to achieve the same effect. This can result in the same disadvantages as above whilst if used in dusty or corrosive applications the valve may stick or corrode.



Hydrokinetic fluid coupling

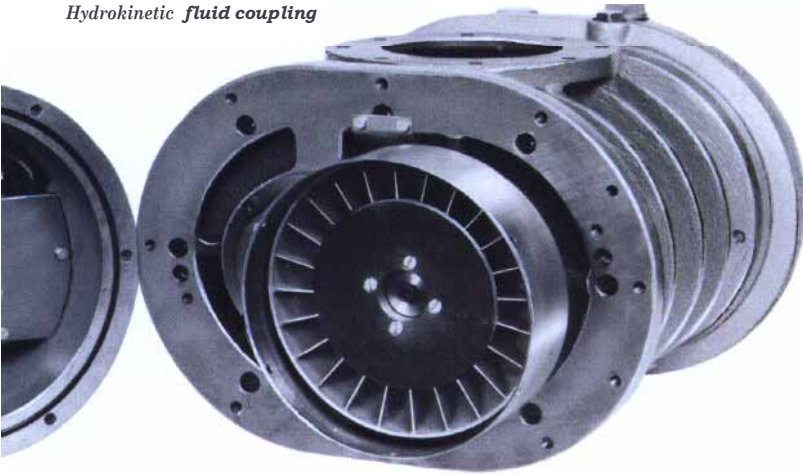

INTEGRITY AND RELIABILITY

The mechanical booster is in principle an oil-free pump as no lubrication or sealing in the pumping mechanism is required. However, the rotors are supported on bearings and accurately geared to each other. These gears and bearings require a lubrication system which presents a potential source of contamination in a clean system. Additionally the lubricant is at risk when aggressive gases or vapours are being pumped.

Integrity

It is essential to prevent oil being transferred from the oil boxes to the pumping chamber and the pumps incorporate an effective seal arrangement.

As shown on the illustration:

1. The bearing is sealed with an integral elastomer seal.
2. A large thrower ring centrifuges off any oil reaching it. Oil drains back to the oil box.
3. A helical labyrinth seal pumps oil reaching it back to the oil box.
4. The inner part of the thrower ring centrifuges the oil back to the helical labyrinth.
5. A dry running shaft seal which is made of PTFE.
6. A felt pad protects the shaft sealing system from dust particles which may be present in the pumping chamber.

A further precaution can be considered by using a chemically inert fluid such as Fomblin, if aggressive gases or oxygen are

being pumped. Flameproof motors can also be supplied for chemical variants.

An alternative design for effective sealing is the canned motor. In this case the rotor is surrounded by a thin non-magnetic can with a closed end. This is sealed into the booster. This form of drive eliminates the shaft seal but has some limitations. Firstly, they usually have smaller motors due to inability to dissipate the heat whilst the can is usually thin with small clearances between the can and the rotor. This can be damaged if particles become trapped.

Magnetic drives overcome some of these problems and can be offered in some applications where hazardous materials are being pumped. Contact Edwards for further information.

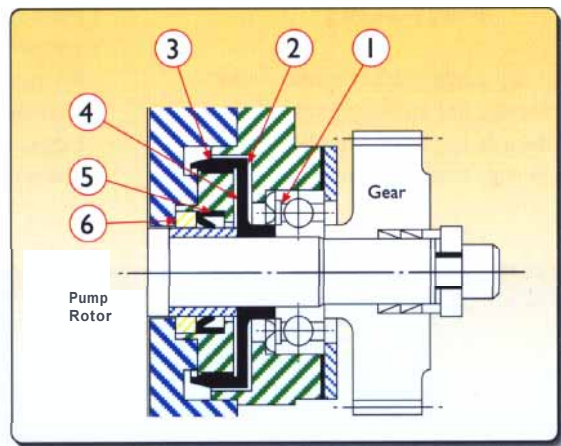

Reliability

In many applications where boosters are operating at inlet pressures between 1 mbar and atmosphere, boosters do a lot of work which result in heat generation which together with heat from back expansion at the exhaust is transmitted to the rotor and stator. Whilst the stator can readily lose heat, the rotor can only lose heat through the shaft to the bearings and this causes differential expansion which can at high thermal loads result in seizure.

Edwards overcome this problem by fitting after coolers to the exhaust of the pump on the EH2600 and EH4200 pumps and all the HV range. In addition internal evacuation of the gear boxes reduces loading on the seals resulting in higher reliability.



BOOSTER PUMP COMBINATIONS AND VACUUM PUMPING SYSTEMS

Edwards comprehensive range of oil sealed and dry vacuum pumps forms the basis for the manufacture of standard booster combinations as well as custom built systems, all being fully tested. These are available in displacements from 300 to 30,000 m³/h and ultimate vacuum down to 10⁻⁴ mbar.

⇒ Edwards - Market leader in dry pumping

As dry pump market leader in the chemical and metallurgical industry, Edwards can offer completely dry running vacuum pumping combinations

utilising our range of chemical DP or industrial GV DRYSTAR pumps as well as our leading range of semiconductor dry pumps.

Standard booster combinations

⇒ Mechanical booster & rotary pump combinations

These systems include EH booster and oil sealed rotary pumps from the EM range. They can offer displacements from 300 to 4,140 m³/h, ultimate vacuum down to 10⁻¹ mbar.

All these systems are standard, and can be ordered with only one item number. Larger systems using HV series boosters are available.

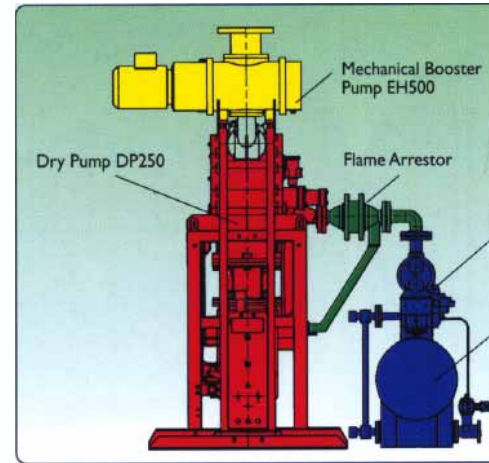

⇒ Mechanical booster & GV DRYSTAR combinations

The industrial GV DRYSTAR pumps can be used in conjunction with a booster pump to increase the pumping speed of the system up to 4,200 m³/h, ultimate vacuum down to 10⁻³ mbar. This type of combinations offers a completely dry running vacuum pumping solution which is particularly used in metallurgy. EH mechanical booster pumps are fitted to the GV pumps using a standard connection kit designed so that the compact foot print of the GV DRYSTAR is maintained. EH/GV combinations can also include standard accessories, such as indirect cooling, acoustic enclosure, air blast cooling, motor control module, gas and water control panels.



BOC EDWARDS

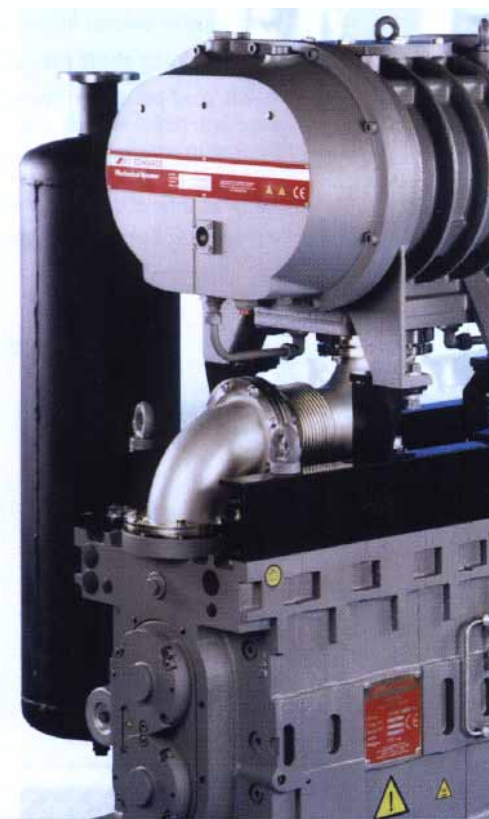

Exhaust
Condenser

Receiver

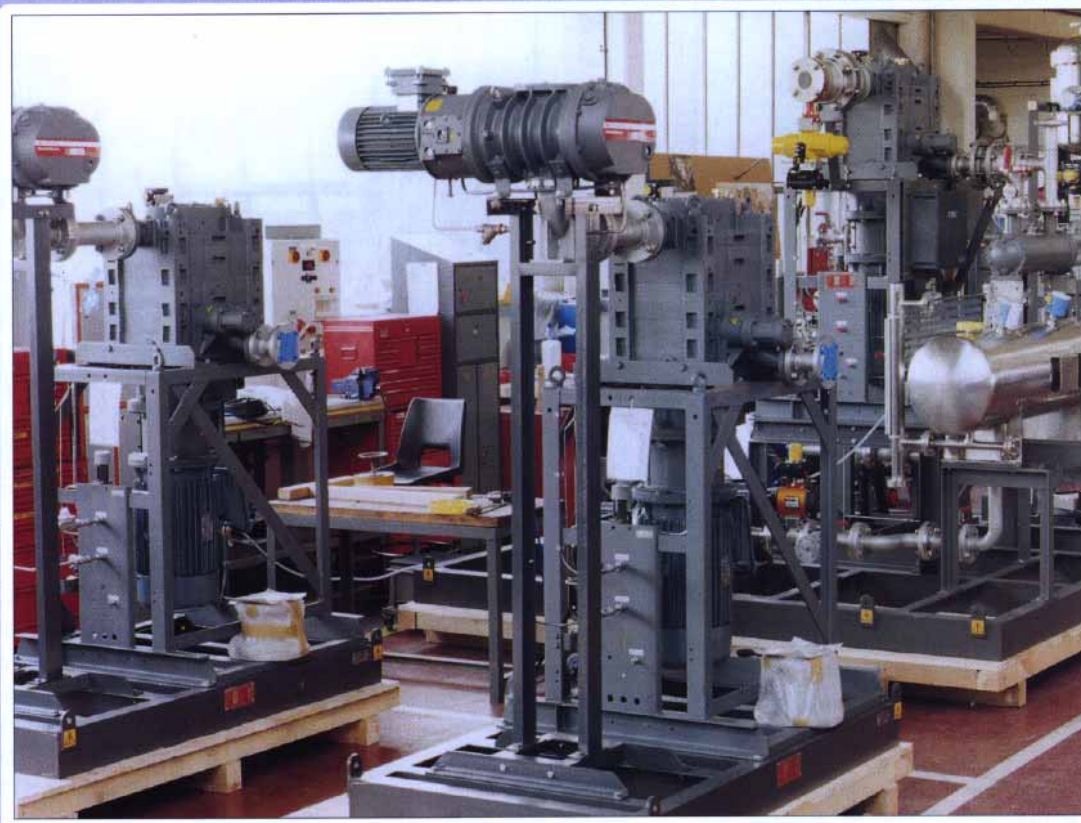

Manufacture of chemical pumping systems

⇒ **Chemical booster pump combinations**

EH pumps can be fitted as standard to our range of 4 chemical dry vacuum pumps of 80,160,250 and 400 m³/h. These combinations increase the pumping capacity up to 4,200 m³/h, with ultimate pressures down to 10⁻² mbar. Standard compact booster frames with pipe-work are available for each of our EH pumps. All pumps are fitted with EExd flame-proof motors to meet safety regulations.

Systemisation - Custom-built pump combinations

Edwards systemisation service offers fully factory tested custom built pump combinations with a wide range of accessories optimised for your application. Edwards experience is broadly based but particularly relevant to vacuum systems for chemical processing, vacuum metallurgy and many other general vacuum applications,





ACCESSORIES, PROTECTION AND CONTROL

Edwards flexible modular approach permits thoroughly engineered design solutions and it allows subsequent expansion or reconfiguration. A wide range of modules and accessories is available to cover requirements in metallurgical, chemical and pharmaceutical processes and many other branches of industry.

Included in the range are customised frames, indirect cooling, acoustic enclosures, air blast coolers, electrical control panels, instrumentation, temperature sensors, isolation and throttle valves, level switches, silencers and acoustic hoods, inverter drives, dust filtration, condensers, receivers, knockout pots, flame arrestors.

Furthermore, Edwards can supply booster pumps with special features like flameproof motors.



The options include:

⇒ Nitrogen purge

Can be fitted to oil boxes to reduce corrosion.

⇒ Thermal *protection*

Thermal snap switches can be fitted as required to switch off the pump in the event of overheating on the EH range of pumps. They are fitted as standard on the HV range of pumps

⇒ Noise reduction

Acoustic enclosures are available for the EH range to reduce the noise level by around 5 dB(A) together with motor mufflers.

⇒ After-coolers

Designed to remove heat and overcome the problems of differential expansion in the exhaust of the booster, EH2600/4200 Series pumps are fitted with nickel plated after-coolers as standard and stainless steel on the HV range. After-coolers are available as option for EH250,500 and 1200.

⇒ Motor control module

Control panels are available for automation of start-up and shutdown and integration with supervisory systems.

⇒ Condensers - Knock out pots

Shell and tube condensers with receivers are available for condensing out vapours prior to the pump. Liquids collected in the receiver can be monitored with level switches and an auto drain facility is available. Where there is a potential for drawing off liquid from the process then knock out pots are available for fitting before the pump.

⇒ Inverter drives

For use with direct drive pumps such as the HV and EDD ranges, enables the pump to be started up under controlled conditions without exceeding the maximum differential pressure across the pump. Can also be used in conjunction with a throttle valve and pressure transmitter to control the pressure in a process.



Technical Data EH Series

	EH250	EH500	EH1200	EH2600	EH4200
Displacement (swept volume)					
50 Hz supply (m ³ /h / ft ³ /min)	310 / 185	505 / 300	1195 / 715	2590 / 1525	4140 / 2440
60 Hz supply (m ³ /h / ft ³ /min)	375 / 220	605 / 355	1435 / 845	3110 / 1830	4985 / 2935
Effective pumping speed with backing pump					
EI/2M40 (m ³ /h / ft ³ /min)	225 / 135	350 / 205	-	-	-
GV80 / DP80 / EI/2M80 (m ³ /h / ft ³ /min)	250 / 150	400 / 235	840 / 495	-	-
GV160 / DP160 (m ³ /h / ft ³ /min)	-	-	950 / 560	-	-
EI/2M175 (m ³ /h / ft ³ /min)	-	-	930 / 550	-	-
GV250 / DP250 / EI/2M275 (m ³ /h / ft ³ /min)	-	-	970 / 570	1900 / 1120	2900 / 1700
GV400 / DP400 (m ³ /h / ft ³ /min)	-	-	-	2000 / 1175	3000 / 1760
Typical ultimate pressure					
with dry vacuum pump (mbar / Torr)			0.01 / 0.0075		
with 2-stage oil-sealed pump (mbar / Torr)			0.001 / 0.00075		
with 4-stage oil-sealed pump (mbar / Torr)			0.01 / 0.0075		
Pressure differential across pump					
50 Hz supply (mbar / Torr)	0 - 180 / 135	0 - 110 / 82	0 - 90 / 67	0 - 80 / 60	0 - 60 / 45
60 Hz supply (mbar / Torr)	0 - 150 / 112	0 - 90 / 67	0 - 75 / 56	0 - 67 / 50	0 - 50 / 37
Electrical supply voltage, 3 phase					
50 Hz	220 - 240V / 380 - 415V (all pumps)				
60 Hz	208 - 230V / 460V (all pumps)				
Motor power (kW)	1,5	1,5	3,0	7,5	7,5
Recommended cooling water flow					
inlet temperature 20°C (l / h)	-	-	120	250	250
Recommended cooling water supply pressure (bar)					
	-	-	2 - 6	2 - 6	2 - 6
Ambient temperature range					
operating (°C)	-40	-40	-40	-40	-40
Recommended oil					
Standard version	Ultragrade 20 (all pumps)				
PFPE version	Fomblin YVAC 16/6 (all pumps)				
Oil capacity					
Gear cover (l)	-	-	1,25	3,5	3,5
Coupling cover (l)	1,5	1,5	2,4	7,3	7,3
Shaft seal reservoir (l)	0,13	0,13	0,13	1,5	1,5
Weight (kg)	61	74	149	308	400

Technical Data HV Series

	HVI1000	HVI4000	HV30000
Displacement (swept volume)			
50 Hz supply (m ³ /h / ft ³ /min)	11.200 / 6.600	14.100 / 8.300	30.000 / 17.700
60 Hz supply (m ³ /h / ft ³ /min)	13.400 / 7.900	16.900 / 9.900	30.000 / 17.700
Effective pumping speed with backing pump			
GV400 / DP400 (m ³ /h / ft ³ /min)	6.900 / 4.100	7.800 / 4.600	13.000 / 7.700
GV400 & EH4200 (m ³ /h / ft ³ /min)	-	-	21.000 / 12.400
Electrical supply voltage, 3 phase			
50 Hz	400 V (all pumps)		
60 Hz	460 V (all pumps)		
Motor power			
50 Hz (kW)	18,5	18,5	30,0
60 Hz (kW)	22,0	22,0	30,0
Recommended oil			
	Edwards Ultragrade 20 (all pumps)		
Oil capacity (l)	20	20	33
Weight (kg)	1.115	1.945	3.100

We reserve the right to change specifications without notice.

EDWARDS

Dimensions EH + HV Series

Pumps are shown with inlet and outlet blanking flanges fitted. Dimensions are to the top surface of the pump flange. Dimensions in mm.

EH250

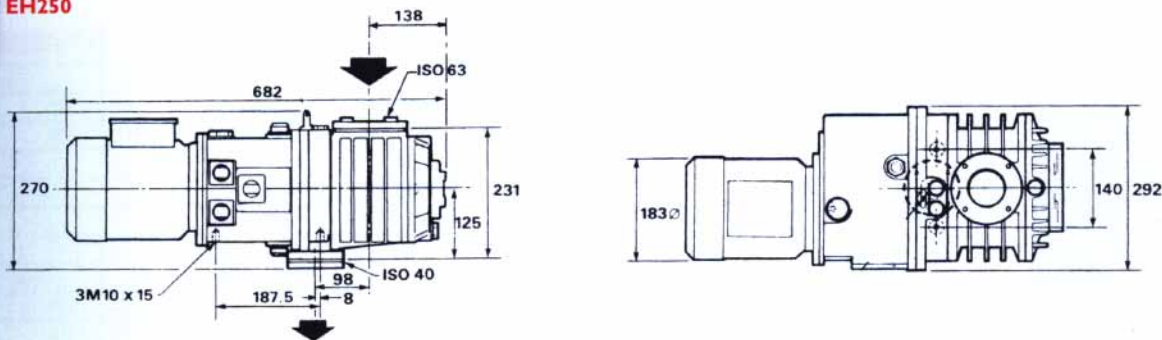

EH500A

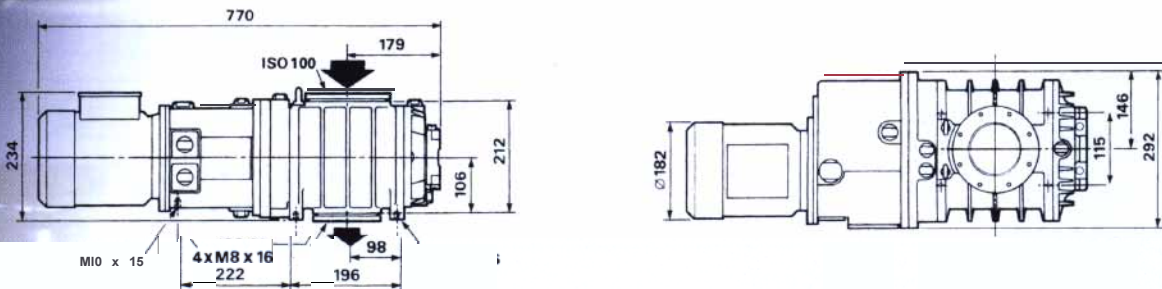

EH1200

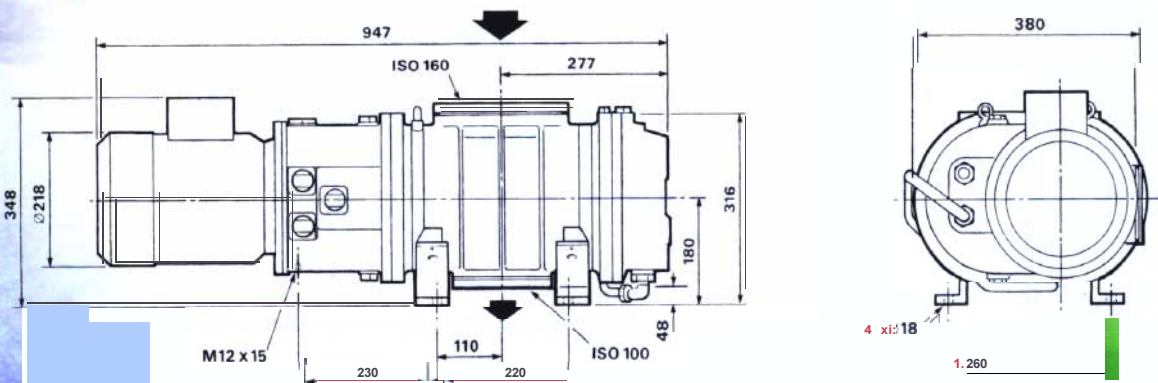

EH2600 + EH4200

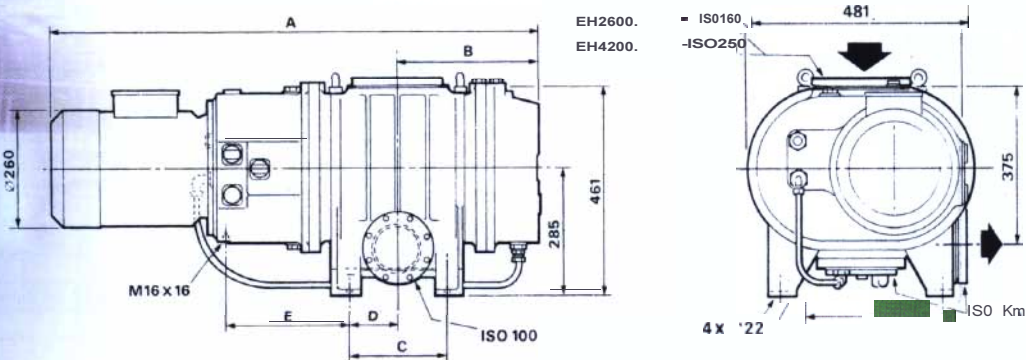

	A	B	C	D	E
EH2600	1093	312	220	110	275
EH4200	1273	402	370	185	290

	A*	B	C	D	E	F	G	H	J	①
HV11000	840	1347	714	390	400	415	290	435	310	350 mm dia bore, 12 holes 22 dia. on 445 pcd off centres
HV14000	840	1547	814	390	400	415	390	435	310	400 mm dia bore, 16 holes 22 dia. on 495 pcd off centres
HV30000	870	1942	1036	490	500	515	490	540	390	500 mm dia bore, 20 holes 22 dia. on 600 pcd off centres

*50 Hz

HV

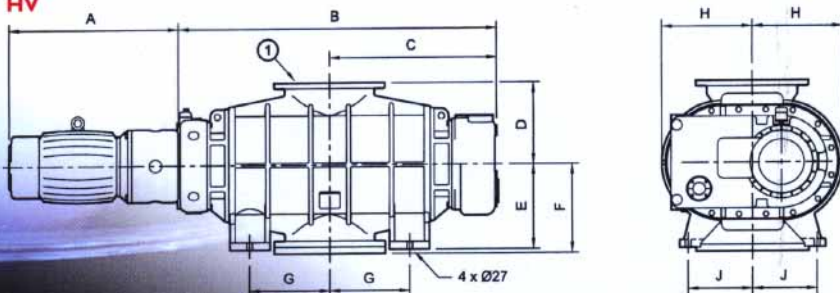

Speed Curves EH + HV Series

60 Hz

50 Hz

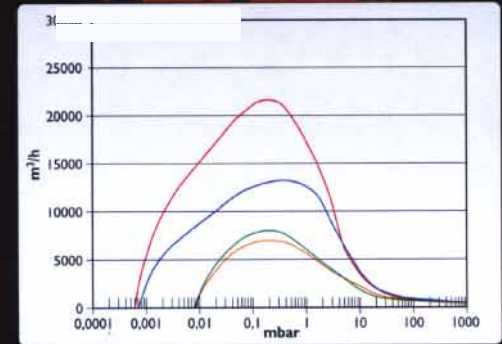
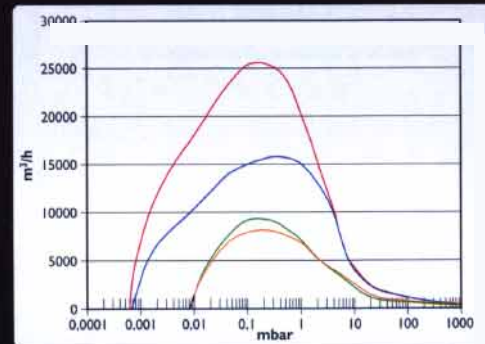
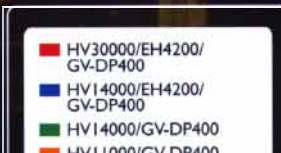
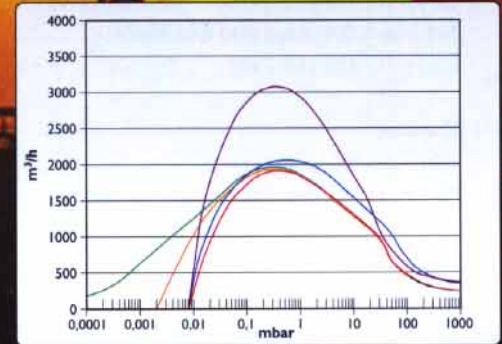
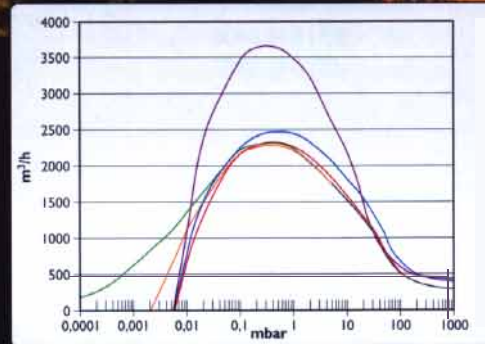
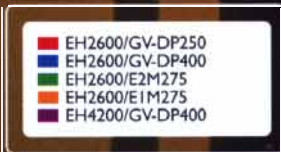
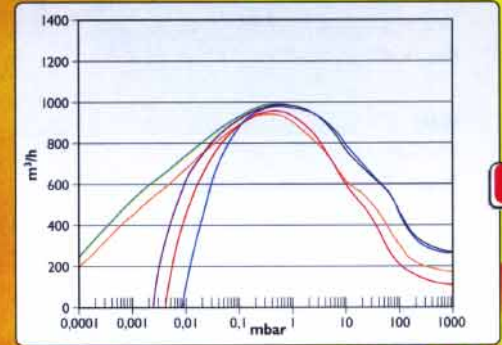
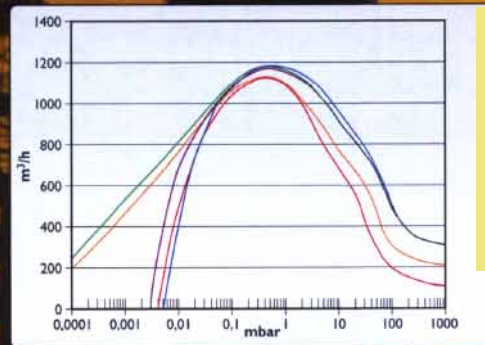
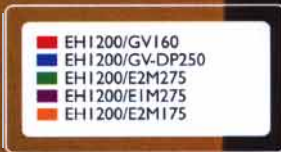
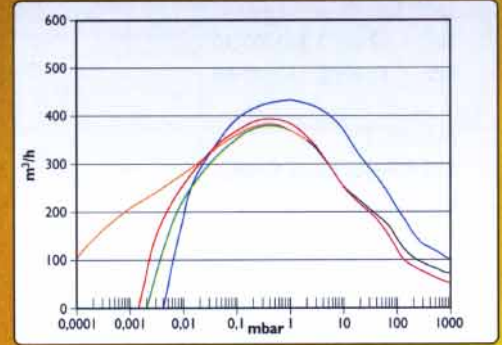
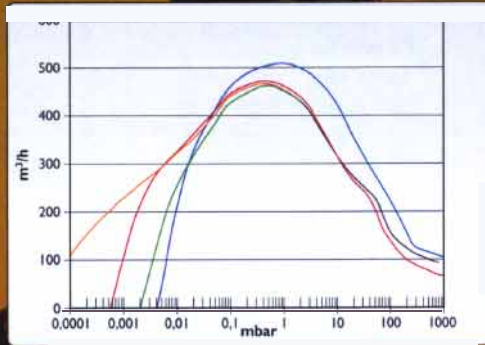
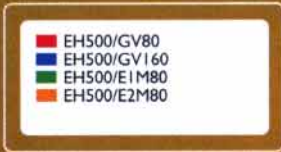
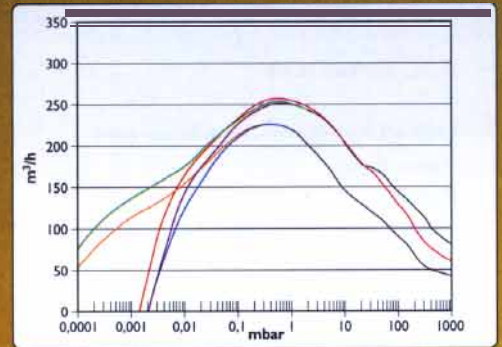
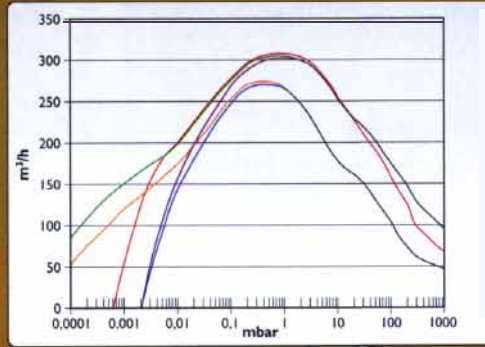
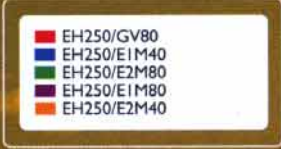

BOC EDWARDS

United Kingdom - Headquarters

Manor Royal
Crawley
West Sussex RH10 2LW
Tel: + 44 (0) 12 93 52 88 44
Fax: + 44 (0) 12 93 53 34 53

Belgium

Bergensesteenweg 709
1600 Sint-Pieters-Leeuw
Tel: + 32 (0) 2 363 00 30
Fax: + 32 (0) 2 363 00 64

France

125 Avenue Louis Roche
92238 Gennevilliers cedex
Tel: + 33 (0) 1 47 98 24 01
Fax: + 33 (0) 1 47 98 44 54

Germany

Ammerthalstraße 36
8555 | Kirchheim
Tel: + 49 (0) 89 99 19 18 0
Fax: +49(0)89 99 19 1888

Italy

Via Carpaccio 35
20090 Trezzano s/n (Milano)
Tel: + 3902484471
Fax: + 39024840 16 38

USA

30 | Ballardvale Street
Wilmington, MA 01887
Tel: + (1) 978 658 5410
Toll free (USA only): 800 848 9800
Fax: + (1) 978 658 7969

Canada

Tel: + (1) 905 336 91 19
Fax: + (1) 905 845 4924

Brazil

Rua Bernardo Wrona 222
Bairro Do Limao
02710 Sao Paulo-SP
Tel: + (55) 11 85 80 37 7
Fax: + (55) 11 26 52 76 6

Japan

Shuwa Shiba Park, Building A-3F
2-4-1 Shibakoen
Minato-Ku
Tokyo 105
Tel: + (81) 3 5470 6530
Fax: + (81) 3 5470 6521

Korea

Daebon Bldg 12 Fl.
720-4 Teoksam-dong
Kangnam-ku
Seoul
Tel: + (82) 2 501 7070
Fax: + (82) 2 561 8181

Hong Kong

2605 Shun Tak Centre
West Wing
200 Connaught Road Central
Hong Kong S.A.R.
Tel: + (852) 2 796 9111
Fax: + (852) 2 796 9095

Singapore

26 Changi South Street 1
Changi South Industrial Estate
Singapore 486773
Tel: + (65) 546 8408
Fax: + (65) 546 8407

<http://www.bocedwards.com>

BOC Edwards is a trading name used by affiliate companies of the BOC Group plc. The stripe symbol is a trademark of the BOC Group plc.

Publication No. 1999-00-895 || MO699
Designed by Körner & Partner, Koblenz
Printed by Brausdruck GmbH, Heidelberg