

APG100 Active Pirani Gauge

Description	Item Number
APG100 - XM NW16	D026-01-000
APG100 - XM NW25	D026-02-000
APG100 - XLC NW16	D026-03-000
APG100 - XLC NW25	D026-04-000



1. Electrical connector
2. Set-point button
3. Cal button
4. Status LED
5. Electronics housing
6. Vacuum flange

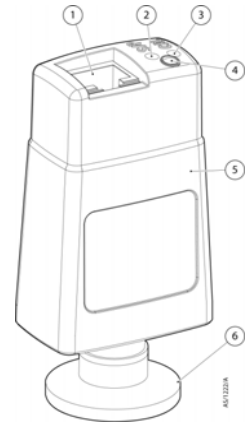

Figure 1 - General view of the APG100

Instruction Manual	
D026-01-880 Iss A	Sep 06

Introduction

Scope and definitions

This manual provides installation, operation and maintenance instructions for the BOC Edwards APG100 Active Pirani Gauge. You must use the APG100 as specified in this manual.

Read this manual before you install and operate the APG100. Important safety information is highlighted as WARNING and CAUTION instructions; you must obey these instructions. The use of WARNINGS and CAUTIONS is defined below.

WARNING
Warnings are given where failure to observe the instruction could result in injury or death to people.

CAUTION
Cautions are given where failure to observe the instruction could result in damage to the equipment, associated equipment and process.

The following symbols appear on the APG100:

Warning - refer to accompanying documents.

BOC Edwards offer European customers a recycling service.

Description

The APG100 is a Pirani gauge which measures vacuum pressures in the range 10⁻⁴ mbar to 1000 mbar. It operates using the principle of thermal conductivity in which the rate of heat loss from a heated filament is dependent on the pressure of gas surrounding the filament.

The APG100 is available in two versions: the 'M' version can measure pressure down to 10⁻³ mbar and is suitable for general applications; the 'LC' version can measure pressure down to 10⁻⁴ mbar and is also suitable for use in corrosive applications.

A general view of the gauge is shown in Figure 1. The gauge features a detachable tube which allows a replacement to be fitted in the event of contamination or failure of the filament. There are two push-button switches on the top of the gauge. The switch labelled "CAL" is used for atmosphere and vacuum calibration and the switch labelled "S/P" is used to adjust the set-point threshold.

Technical Data

Mechanical data

Dimensions Refer to Figure 2

Mass:	NW16 versions 85 g
	NW25 versions 100 g
Internal volume of tube	5 cm ³
Enclosure rating	IP40

Performance, operating and storage conditions

Measurement range	APG100-XM 10 ⁻³ to 1000 mbar
	APG100-XLC 10 ⁻⁴ to 1000 mbar
Accuracy	APG100-XM typically ± 15 % at < 100 mbar
	APG100-XLC typically ± 15 % at < 10 mbar
Ambient temperature	Operating 5 to 60 °C
	Storage -30 to +70 °C
Bakeout temperature	150 °C (with electronics housing removed)
Humidity	80 % RH up to 31 °C decreasing linearly to 50 % RH at 40 °C and above
Maximum altitude	3000 m (indoor use only)
Maximum internal pressure	10 bar absolute (9 bar gauge)
Filament temperature	100 °C above ambient

Electrical data

Electrical supply voltage	15 to 30 V d.c. nominal
	13.5 V minimum
	32 V maximum
Maximum power consumption	1 W
Max inrush current	150 mA
Electrical connector	FCC68 / RJ45 8-way
Pressure output signal	Range 1.9 to 9.1 V
	Error range output < 1.8 V or output > 9.2 V
	Min load impedance 10 kΩ
	Max output current 1 mA
Set-point	Adjustment range 1.8 to 9.2 V
	Hysteresis 500 mV
	Max external load rating 30 V d.c., 100 mA
Gauge identification resistance	APG100-XM 36 kΩ
	APG100-XLC 43 kΩ

Materials exposed to vacuum

Filament	Tungsten / Rhenium
APG100-XM	Platinum / Iridium
APG100-XLC	Stainless Steel 316L & 304L
Tube	Stainless Steel 316L
Filter	Glass, Ni, NiFe, PTFE (APG100-XLC only)
Other	

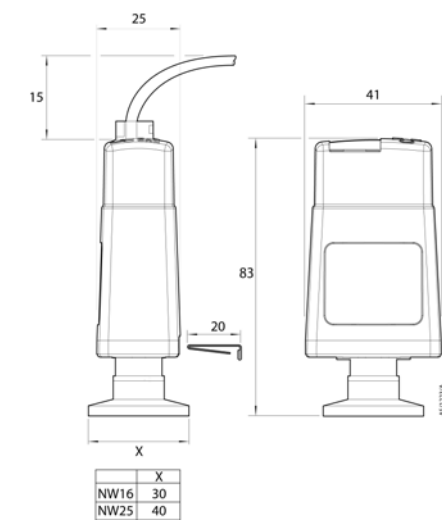

Figure 2 - Dimensions (mm)

Installation

Unpack and inspect

Remove all packing materials and protective covers. Check the APG100. If the APG100 is damaged, notify your supplier and carrier in writing within three days: state the Item Number of the gauge together with your order number and your suppliers invoice number. Retain all packing materials for inspection. Do not use the APG100 if it is damaged.

If the APG100 is not to be used immediately, replace the protective covers. Store the APG100 in suitable conditions as described in Technical Data section.

Fit the APG100 to a vacuum system

WARNING
You must use a Co-seal or trapped 'O' ring carrier to connect an APG100 to a vacuum system if the pressure is likely to exceed atmospheric pressure. Standard centring rings are not suitable for use above atmospheric pressure.

WARNING
Do not use the APG100 for safety critical applications. The APG100 is not intended to be fail-safe.

The APG100 can be mounted in any orientation however the gauge tubes are individually factory calibrated in nitrogen whilst vertical. For correct pressure indication in your chosen gauge orientation, the gauge should be recalibrated at atmospheric pressure. BOC Edwards recommends mounting the gauge tube vertical in order to minimise the build up of process particulates and condensable vapours within the gauge.

For optimum accuracy it is recommended that both the atmosphere and vacuum adjustment is carried out before use. Refer to the Maintenance section.

To connect the APG100 to your vacuum system:

- Use an 'O' ring / centring-ring or Co-Seal to connect an APG100 with an NW16 or NW25 flange to a similar flange on the vacuum system.
- Use a stepped 'O' ring carrier or Co-Seal to connect an APG100 with an NW16 flange to an NW10 flange.

In accordance with good practice, we recommend that your vacuum system has a secure Earth (ground) connection, and that the tube of the APG100 is electrically connected to the vacuum system.

Connect to a BOC Edwards Controller

The APG100 is compatible with the TIC and ADC digital controllers and the AGD analogue display from BOC Edwards. The controllers will automatically recognise the gauge and display the measured pressure.

To connect to a BOC Edwards controller use a cable which is terminated in suitable connectors. These cables are available from BOC Edwards.

Connect to your own electrical equipment

CAUTION
Do not make any connection to the gauge identification pin (pin 4) as this may cause the gauge to malfunction.

A schematic diagram of the recommended electrical connections to the APG100 is shown in Figure 4. The pins on the electrical connector are used as shown in Table 1. Refer to the Technical Data section for more detailed specifications.

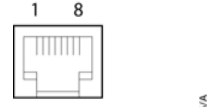
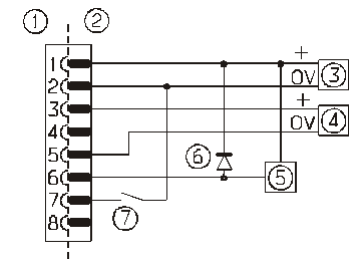

Figure 3 - RJ45 8-way connector

Pin number	Use
1	Electrical supply positive
2	Electrical supply ground (0 V)
3	Pressure measurement output signal
4	Gauge identification
5	Signal ground
6	Set-point output signal
7	Remote calibration input
8	Not connected

Table 1 - Pins on the APG100 electrical connector



1. APG100 electrical connector socket
2. Cable electrical connector plug
3. Electrical supply
4. Voltmeter
5. d.c. relay (optional)
6. Back EMF suppression diode (optional)
7. Remote calibration switch (optional)

Figure 4 - Recommended electrical connections

Do not connect the electrical supply ground (pin 2) to the signal ground (pin 5). If you do, the APG100 output signal will be inaccurate.

When using the APG100 in an electrically noisy environment you should ensure that your measuring equipment is adequately immune to interference. All BOC Edwards controllers have adequate immunity.

The set-point output on pin 6 is an active low open-collector transistor suitable for driving a d.c. relay or control logic. If you connect a relay you must use a suppression diode, to protect the gauge from transient voltages generated when the relay is switched off, as shown in Figure 4.

Make a connection to pin 7 if you require remote calibration. Momentarily (>50ms) connect pin 7 to pin 2 (ground) to automatically adjust the atmosphere or vacuum reading. Refer to the Maintenance section for the correct procedure.

Operation

WARNING
Do not use the APG100 to measure the pressure of explosive or flammable gasses or mixtures. The gauge contains a heated filament which normally operates around 100°C above ambient temperature. The temperature of the filament can be substantially higher under fault conditions.

Pressure measurement

When the APG100 is connected to a power supply the status LED will turn amber for approximately 2 seconds. The status LED will then turn green if the gauge is operating correctly or red if an error is detected. Refer to the fault finding guide.

If the gauge is connected to a BOC Edwards controller the display will indicate the measured pressure.

If the gauge is connected to a voltmeter convert the voltage (V) to pressure (P) using the following equations:

$$P = 10^{(V-6)}$$

$$P = 10^{(V-6.125)}$$

$$P = 10^{(V-4)}$$

$$P \text{ in mbar}$$

$$P \text{ in Torr}$$

$$P \text{ in Pa}$$

For example if the measured voltage V = 4 V, then the measured pressure P = 1 x 10⁻² mbar. Refer to Figures 5 and 6.

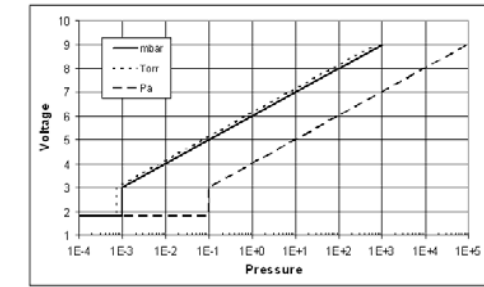

Figure 5 - Voltage to pressure conversion for APG100-XM

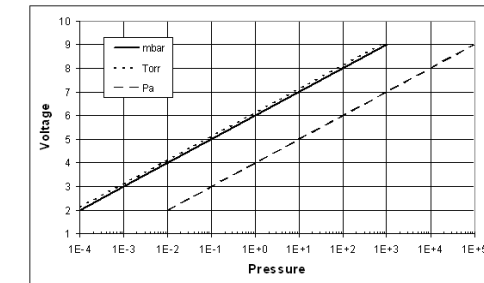

Figure 6 - Voltage to pressure conversion for APG100-XLC

Gas dependency

The APG100 is calibrated for use in nitrogen, and will read correctly with dry air, oxygen and carbon monoxide. For any other gas type a conversion is required in order to obtain the correct pressure reading. Figures 7 and 8 show the conversion for 6 common gases: nitrogen, argon, carbon dioxide, helium, krypton and neon.

If you are using a BOC Edwards TIC controller, the gas calibration data is built into the controller.

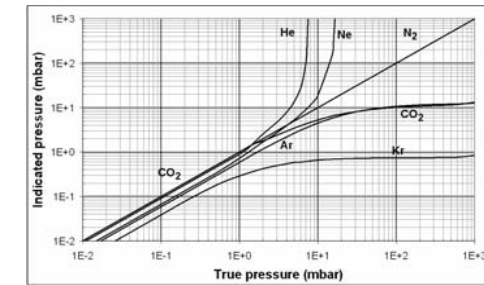

Figure 7 - Gas dependency of APG100-XM

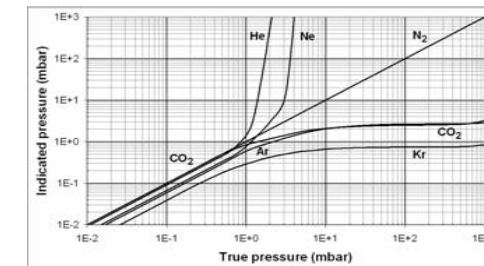

Figure 8 - Gas dependency of APG100-XLC

PLEASE CONTACT ANY OF THESE COMPANIES FOR DETAILS OF OTHER SALES AND SERVICE CENTRES IN YOUR AREA.

EUROPE/ UNITED KINGDOM
BOC EDWARDS
Manor Royal
Crawley
West Sussex
RH10 9LW
Tel +44 (0)1293 528844
Fax +44 (0)1293 533453

CANADA
BOC EDWARDS
5975 Falbourne Street
Mississauga, Ontario L5R3W6
Canada
Tel +1 800 387 4076
Fax +1 905 501 1225

ITALY
BOC EDWARDS
Via Carpaccio 35
20090 Trezzano sul Naviglio
Milan
Tel +39 02 48 4471
Fax +39 02 48 401638

AMERICAS
USA HEADQUARTERS
BOC EDWARDS
One Edwards Park
301 Ballardvale Street
Wilmington, MA 01887
Tel +1 978 658 5410
Fax +1 978 658 7969
Toll free (USA only) 1 800 848 9800

GERMANY
BOC EDWARDS
Ammerthalstraße 36
85551 Kirchheim
Munich
Tel +49 89 991 9180
Fax +49 89 991 91899

BOC EDWARDS
Wilhelm Klein GmbH
Eckenerstrasse 1
D-73730 Esslingen
Postfach 10 03 28
Tel +49 (0)711/93 18 30-0
Fax +49 (0)711/93 18 30-3

FRANCE
BOC EDWARDS
125 Avenue Louis Roche
92238 Gennevilliers, Cedex
Paris
Tel +33 1 47 98 24 01
Fax +33 1 47 98 44 54

BELGIUM
BOC EDWARDS
Bergensesteenweg 709
B1600 Sint-Pieters-Leeuw
Brussels
Tel +32 2 363 0030
Fax +32 2 363 00640

INDIA
BOC EDWARDS
INDIA HEADQUARTERS
203 Surya Kiran Building
19 Kasturba Gandhi Marg
New Delhi - 110 001
India
Tel +91 11 5151 0065
Fax +91 11 5151 0245

ISRAEL
EDWARDS ISRAEL VACUUM LTD
5 Habarzel Boulevard
Gat 2000 Industrial Zone
Qiryat Gat 82000
Israel
Tel +972 8 681 0633
Fax +972 8 681 0640

BRAZIL
BOC DO BRASIL LTDA
Rua Bernardo Wrona 222
02710 São Paulo-SP
Brazil
Tel +55 11 3952 5000
Fax +55 11 3965 2766

JAPAN
HEADQUARTERS
BOC EDWARDS
5F Sانشيكاikan Building
1-9-4 Yurakucho Chiyoda-Ku
Tokyo, 100-0006
Tel +81 (0)3 6212 6771
Fax +81 (0)3 6212 6780

CHINA
BOC TRADING
(SHANGHAI) CO. LTD.
23 Fu Te Road (N)
Wai Gao Qiao Free Trade Zone
Pudong
Shanghai, 200131
PRC China
Tel +86 21 5866 9618
Fax +86 21 5866 9993

KOREA
HEADQUARTERS
SONGWON EDWARDS LTD.
5th FL. Daewoo Engineering Bldg.
9-3 Sunae-dong
Kyungki-do
Korea
Tel +82 31 716 7070
Fax + 82 31 738 1001

TAIWAN, R.O.C.
EDWARDS TAIWAN LIMITED
No. 434 Chung hua Road
Toufen Town, Miaoli County
351 Taiwan
Tel +886 37 611422
Fax +886 37 611401

SINGAPORE
BOC EDWARDS (ASIA)
42 Loyang Drive
Loyang Industrial Estate
Singapore 508962
Tel +65 6546 8408
Fax +65 6546 8407

EDWARDS TAIWAN LIMITED
No. 434 Chung hua Road
Toufen Town, Miaoli County
351 Taiwan
Tel +886 37 611422
Fax +886 37 611401

BOC Edwards is part of BOC Limited. BOC Edwards and the stripe symbol are trade marks of The BOC Group.
© BOC Edwards 2005

www.bocedwards.com
info@bocedwards.com

