

Instruction Manual

Active Ion Gauge

Description

AIGX - S - NW25
AIGX - S - DN16CF
AIGX - S - DN40CF

Item Number

D048-50-000
D048-51-000
D048-52-000



Declaration of Conformity

We, BOC Edwards,
Manor Royal,
Crawley,
West Sussex RH10 2LW, UK

declare under our sole responsibility that the product(s)

Active Ion Gauge	
AIGX-S-NW25	D048-50-000
AIGX-S-DN16CF	D048-51-000
AIGX-S-DN40CF	D048-52-000

to which this declaration relates are in conformity with the following standard(s)
or other normative document(s)

EN61010-1:2000	Safety Requirements for Electrical Equipment for Measurement, Control and Laboratory Use.
EN61326:1997 + A1:1998 + A2:2001 (Industrial environment, Class B Emissions)	Electrical Equipment for Measurement, Control and Laboratory Use - EMC Requirements.

following the provisions of

89 / 336 / EEC	Electromagnetic Compatibility Directive.
----------------	--

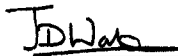

Dr. J.D. Watson, Director of Technology, VEMD

2 September 2004 Shoreham

Date and Place

This product has been manufactured under a quality system registered to ISO9001

CONTENTS

Section	Title	Page
1	INTRODUCTION	1
1.1	Scope and definitions	1
1.2	Description	1
2	TECHNICAL DATA	4
2.1	Mechanical data	4
2.2	Performance, operating and storage conditions	4
2.3	Electrical data	4
2.3.1	Electrical supply	4
2.3.2	Output signal	4
2.3.3	Gauge and degas enable	5
2.3.4	Set-point	5
2.3.5	Gauge identification	5
2.3.6	Electrodes	5
2.4	Materials exposed to vacuum	5
3	INSTALLATION	7
3.1	Unpack and inspect	7
3.2	Fit the AIGX to the vacuum system	7
3.3	Electrical connections	7
3.3.1	Connect to BOC Edwards AGC	8
3.3.2	Connect to your own supply and control equipment	8
3.3.3	Maximum cable length	10
4	OPERATION	11
4.1	Enable and disable the AIGX	11
4.2	Pressure measurement	12
4.2.1	Calibration in different gases	12
4.3	Emission current	14
4.4	Degas the AIGX	14
4.5	Over-pressure protection	14
4.6	Filament selection	15
4.7	LED status	15
4.8	Set-point adjustment	15
4.9	Error indication	16
4.10	Bakeout	16

Section	Title	Page
5	MAINTENANCE	18
5.1	Fault finding guide	18
5.2	Replace the body tube	19
5.3	Replace the internal fuse	19
5.4	Calibration service	20
6	STORAGE AND DISPOSAL	21
6.1	Storage	21
6.2	Disposal	21
7	SPARES AND ACCESSORIES	22
7.1	Introduction	22
7.2	Spares	22
7.3	Accessories	23

RETURN OF BOC EDWARDS EQUIPMENT

Illustrations

Figure	Title	Page
1	General view of the AIGX (NW25 version)	3
2	Dimensions (mm)	6
3	Schematic diagram of recommended electrical connections	9
4	Pressure output signal of AIGX	13
5	Separate the electronics housing from the body tube	17
6	Fuse replacement	20

Tables

Table	Title	Page
1	Pins on the AIGX connector	8
2	Maximum recommended cable length	10
3	Gas calibration factors for various gases	12
4	LED status	15
5	Error indication	16
6	Fault finding guide	18

1 INTRODUCTION

1.1 Scope and definitions

This manual provides installation, operation and maintenance instructions for the BOC Edwards Active Ion Gauge (AIGX). You must use the AIGX as specified in the manual.

Read this manual before you install and operate the AIGX. Important safety information is highlighted as **WARNING** and **CAUTION** instructions; you must obey these instructions. The use of **WARNINGS** and **CAUTIONS** is defined below.

WARNING

Warnings are given where failure to observe the instruction could result in injury or death to people.

CAUTION

Cautions are given where failure to observe the instruction could result in damage to the equipment, associated equipment or process.

The units used throughout this manual conform to the SI international system of units of measurement.

The following symbols appear on the AIGX:



Warning (refer to accompanying documents)



From August 2005, BOC Edwards will offer European customers a recycling service.

1.2 Description

The AIGX is an ion gauge head and gauge controller in a single compact unit. The gauge operates as a hot filament ionisation gauge, in which the pressure is measured indirectly as a function of the current.

The measurement range of the AIGX is 5×10^{-10} to 5×10^{-2} torr (6.6×10^{-10} to 6.6×10^{-2} mbar). Three types of vacuum connections are available: DN16CF, DN40CF and NW25.

The AIGX requires a 14.5 - 30 V d.c. power supply; it has a 0 to 10 V d.c. analogue output which is related to pressure. The AIGX is compatible with the BOC Edwards Active Gauge Controller (AGC). Alternatively, you can use an independent power supply and you can read the output signal with a voltmeter or analogue to digital converter.

An 8-way electrical connector socket on the AIGX (Figure 1, item 1) is used to connect the AIGX to your AGC or electrical supply and voltmeter. Electrical cables fitted with suitable connectors are available as accessories. A gauge identification signal is available on the electrical connector: this signal is used by BOC Edwards AGC's to identify which type of active gauge is connected.

The AIGX is supplied with two filaments. A switch on top of the gauge selects between filament 1 and 2 (Figure 1, item 2).

There are two levels of emission currents: 0.1 and 1 mA. The gauge will automatically select 1 mA emission current at low pressure, and 0.1 mA at high pressure.

A protection circuit is built into the gauge to prevent operating the gauge at pressures higher than 5×10^{-2} torr.

The AIGX can be degassed using the degas feature. During degas, the grid voltage is 500 V and the emission current is 10 mA. The degas is inhibited at high pressure. The maximum duration of degas is three minutes, after which the gauge returns automatically to its normal mode.

The AIGX has a set-point facility. The set-point signal is an open collector transistor output, which is on when the pressure measured by the gauge is below a preset pressure. The pressure at which the set-point operates can be adjusted using the set-trip switch on the top of the gauge (Figure 1, item 3).

The AIGX is fitted with a status LED (Figure 1, item 4). This LED indicates the operating status of the gauge.

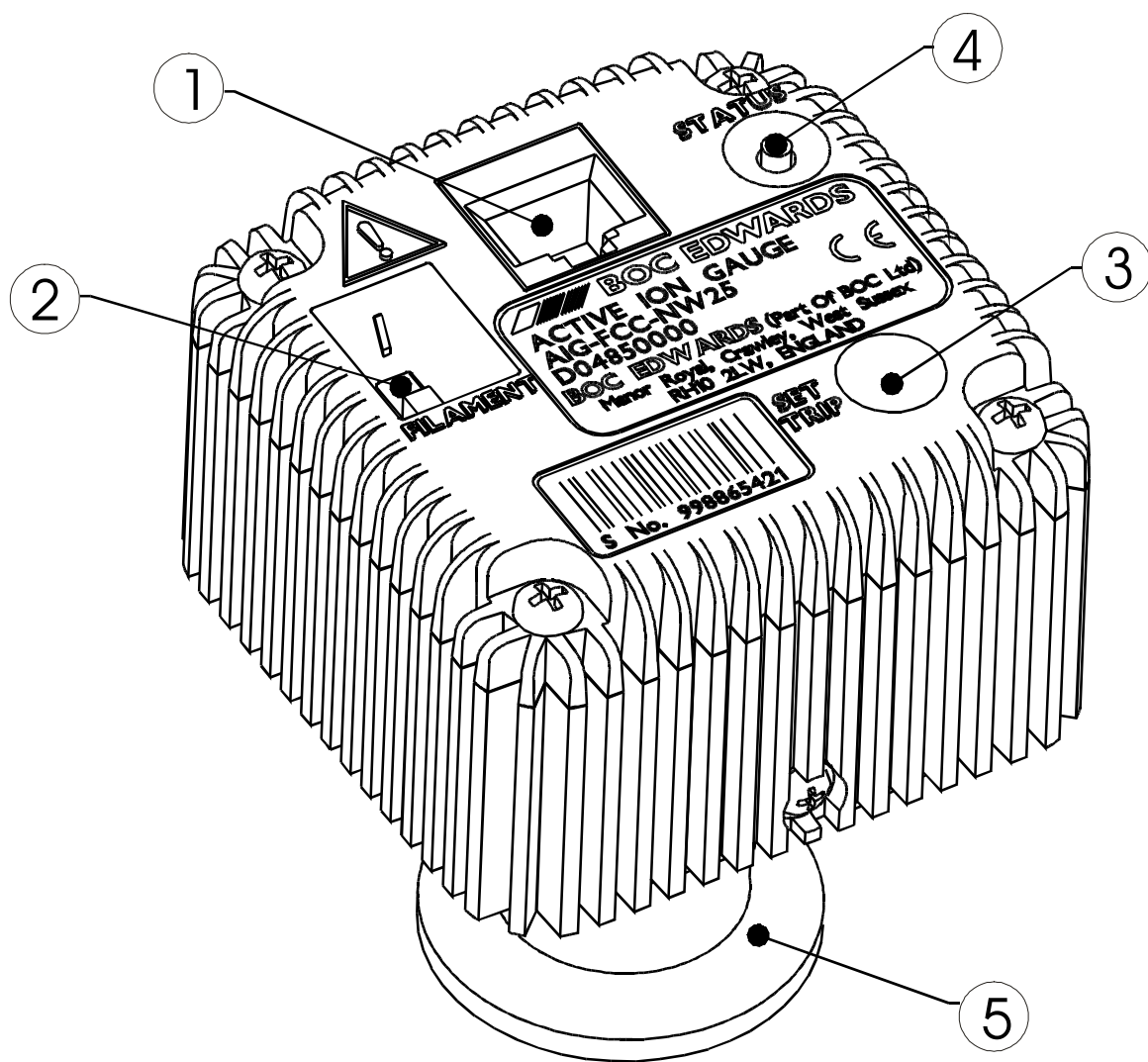

- | | | | |
|----|------------------------|----|---------------|
| 1. | Electrical connector | 4. | Status LED |
| 2. | Filament select switch | 5. | Vacuum flange |
| 3. | Set trip switch | | |

Figure 1 - General view of the AIGX (NW25 version)

2 TECHNICAL DATA

2.1 Mechanical data

Dimensions	See Figure 1
Mass	
AIGX-S-NW25	260 g
AIGX-S-DN16CF	300 g
AIGX-S-DN40CF	510 g
Volume of gauge tube	21 cm ³
Enclosure rating	IP30

2.2 Performance, operating and storage conditions

Ambient temperature	
operation	0 to 40 °C
storage	-30 to 70 °C
Ambient humidity	90% RH (non-condensing) up to 31 °C reducing to 50 % RH at 40 °C
Bakeout temperature	200 °C (with electronics removed)
Maximum operating altitude	2000 m
Maximum internal pressure	10 bar absolute
Pressure measurement range	5 x 10 ⁻¹⁰ to 5 x 10 ⁻² torr (6.6 x 10 ⁻¹⁰ to 6.6 x 10 ⁻² mbar)

2.3 Electrical data

2.3.1 Electrical supply

Voltage	+14.5 V to +30 V d.c.
Internal fuse	1 A (T)
Maximum power consumption	
Operating	7 W
Degas	14 W
Electrical connector	FCC 68 (RJ45)

2.3.2 Output signal

Measurement range	0.7 V to 8.7 V
Gauge disabled	9.0 V
Emission error	9.5 V
Over-pressure trip	9.7 V
Minimum load impedance	10 kΩ

2.3.3 Gauge and degas enable

Control sense	Active low
Active level	< 1.5 V

2.3.4 Set-point

Trip level	0.6 V to 8.8 V
Hysteresis	500 mV
Set-point output load rating	30 V d.c., 100 mA max
Back EMF suppression diode *	
Min surge rating	1 A
Min reverse voltage rating	100 V

* required when you use an external d.c. relay connected to the set-point output

2.3.5 Gauge identification

Identification resistance	162 k Ω
---------------------------	----------------

2.3.6 Electrodes

Emission current	
Normal	0.1 or 1 mA
Degas	10 mA
Grid voltage	
Normal	180 V
Degas	500 V
Filament bias voltage	+ 30 V
Collector voltage	0 V

2.4 Materials exposed to vacuum

Collector	Tungsten
Grid	Tantalum Pt Clad Mo
Filament	Yttria coated iridium
Body	Stainless Steel
Feedthrough	Stainless Steel and UHV compatible, glass/ceramic

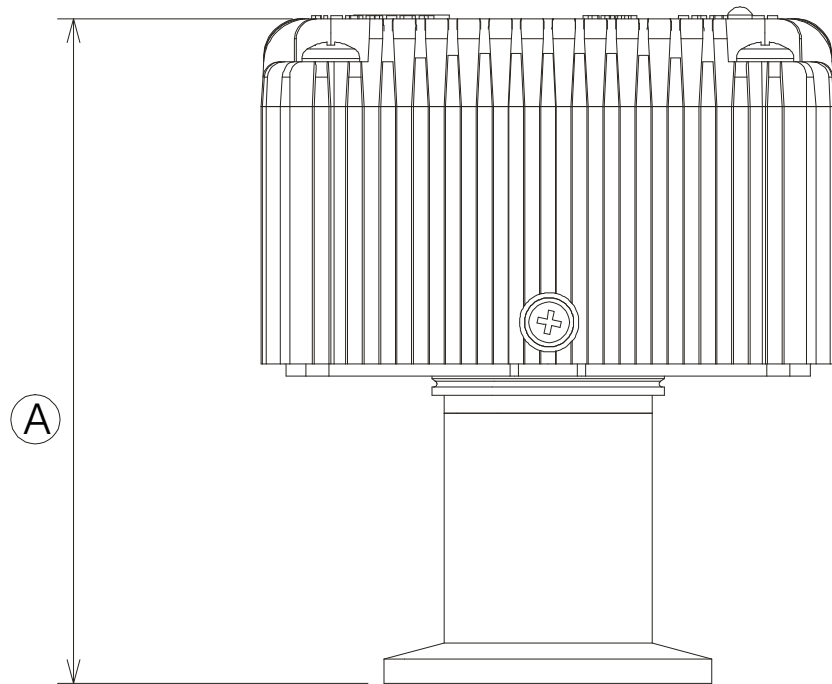

	A
NW25	85
DN16CF	106
DN40CF	98

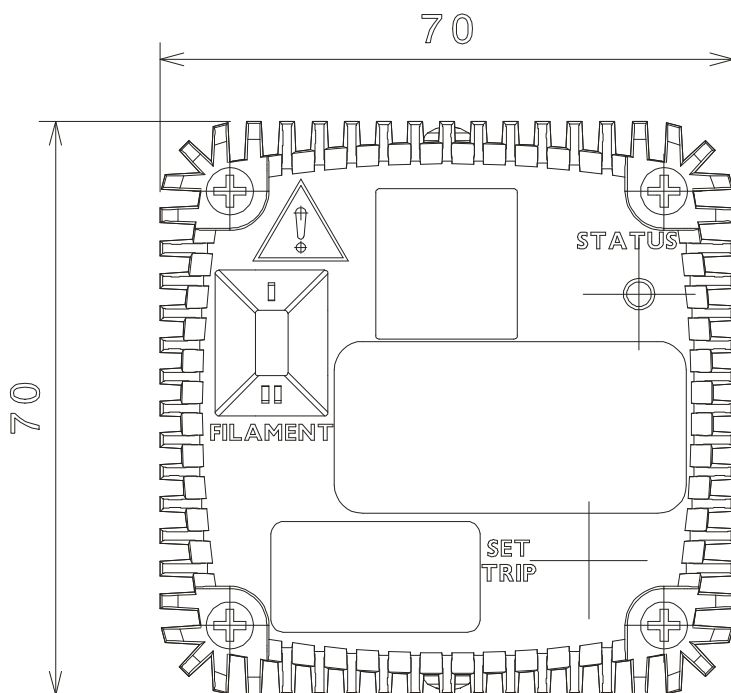

Figure 2 - Dimensions (mm)

3 INSTALLATION

3.1 Unpack and inspect

Remove all packing materials and protective covers and check the AIGX .

If the AIGX is damaged, notify your supplier and the carrier in writing within three days; state the Item Number of the gauge together with your order number and your supplier's invoice number. Retain all packing materials for inspection. Do not use the AIGX if it is damaged.

If the AIGX is not to be used immediately, replace the protective covers. Store the AIGX in suitable conditions as described in Section 6.

3.2 Fit the AIGX to the vacuum system

The AIGX can be mounted in any orientation. To avoid the build-up of debris or condensable material in the body tube of the AIGX (which will probably cause pressure measurement errors), we recommend that you install the AIGX vertically with the flange facing down.

Use a copper gasket and screws to connect the DN16CF and DN40CF flanges of the AIGX to a similar flange on your vacuum system. Use an 'O' ring / centring-ring or Co-Seal and metal clamp to connect the NW25 flange of the AIGX to a similar flange on your vacuum system.

Note: 'O' rings are not recommended for systems where UHV pressures are required.

3.3 Electrical connections

WARNING

The AIGX must be connected to an earthed (grounded) vacuum system. For gauges with a NW25 flange, a conductive metallic clamping ring must be used.

WARNING

If the AIGX malfunctions, the AIGX pressure output may be incorrect. If such a failure could result in damage to equipment or cause injury to people, you must install a suitable control system to indicate the failure and, if necessary, to close down your process system.

3.3.1 Connect to BOC Edwards AGC

Connect the AIGX to the AGC using a cable which is terminated in suitable connectors. Suitable cables are available from BOC Edwards. Refer to Section 7.3.

Note: Your AGC must have a version of software that is compatible with the AIGX. If the AGC display shows ??? when the AIGX is plugged in, then an upgrade to the AGC software is required. Please contact BOC Edwards.

Note: For cable lengths exceeding 10 m, cables with a larger conductor cross-section are required.

3.3.2 Connect to your own supply and control equipment

Note: Do not connect the electrical supply common (pin 2) to the signal common (pin 5). If you do, the AIGX pressure output signal will be inaccurate.

A schematic diagram of the recommended electrical connections to the AIGX is shown in Figure 3.

The pins on the AIGX connector are used as shown in Table 1. The specification of the electrical supply, d.c. relay and back EMF suppression diode are given in Section 2.

Pin No.	Use
1	Supply positive
2	Supply common
3	Signal output
4	ID resistor
5	Signal common
6	Degas enable
7	Gauge enable
8	Set-point output

Table 1 - Pins on the AIGX connector

The connection to Pin 8 is optional. Make the connection to Pin 8 if you want to connect the set-point output signal to a d.c. relay. You must connect a suppression diode between pins 8 and 1 to protect the AIGX from transient voltage generated when the d.c. relay is switched off.

Connect a switch between pins 7 and 2 to enable and disable the gauge.

Connect a switch between pin 6 and 2 to enable and disable the degas function.

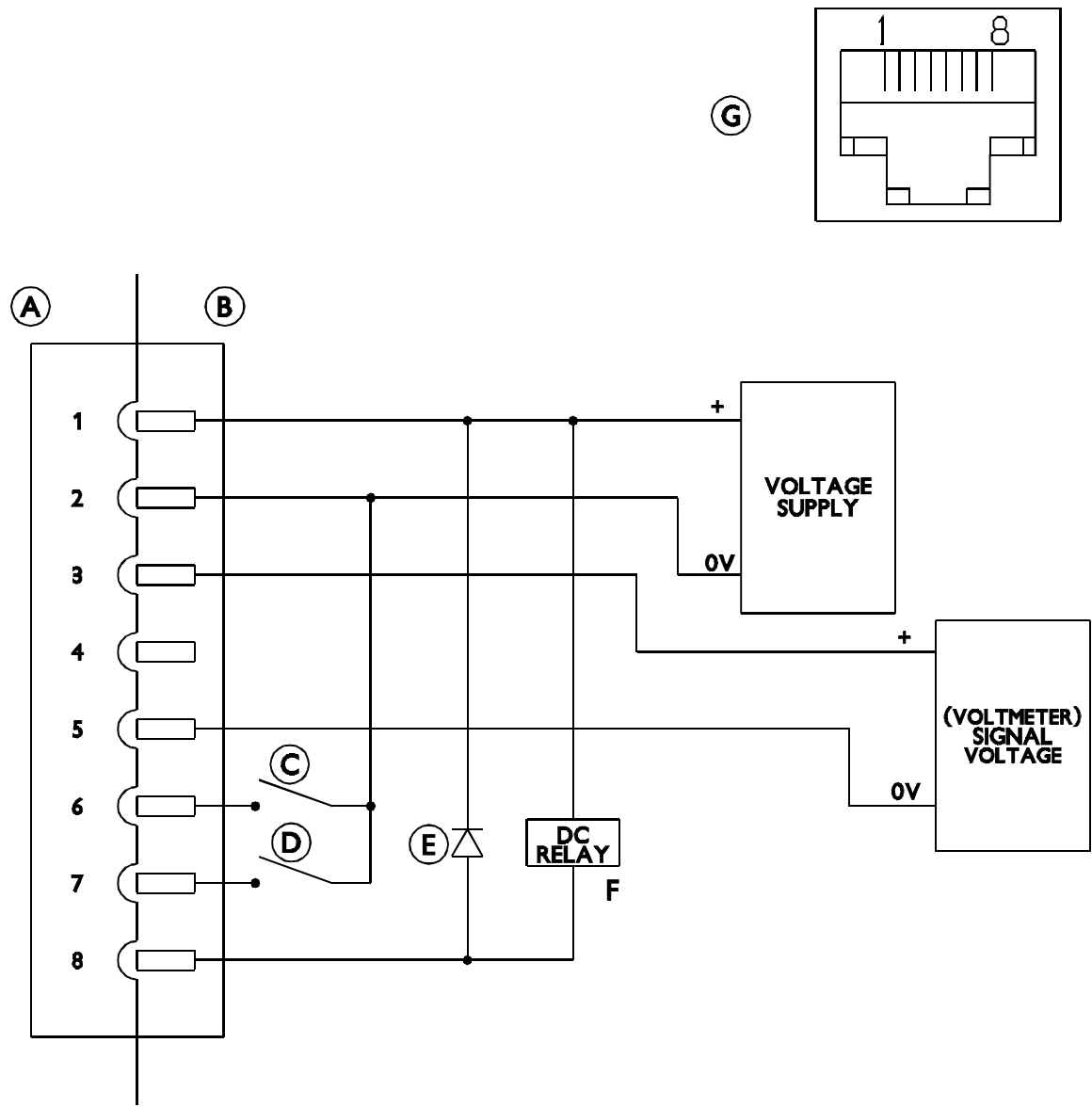

KEY

- A AIGX connector (socket)
- B Cable electrical (plug)
- C Degas enable switch
- D Gauge enable switch
- E Back EMF suppression diode (optional)
- F D.C. relay (optional)
- G View of AIGX connector

Figure 3 - Schematic diagram of recommended electrical connections

3.3.3 Maximum cable length

The maximum cable length is dependent on the conductor cross-section and the supply voltage used. The following maximum cable lengths are recommended:

Conductor cross-section	24 V Supply	15 V Supply
24 awg	30 m	0.5 m
28 awg	10 m	1 m

Table 2 - Maximum recommended cable length

The common mode signal voltage (that is, the voltage between signal common and supply common) could be as much as 2.5 V with long cables due to the voltage drop in the supply cable. You should ensure that the signal voltage measurement will operate correctly.

4 OPERATION

WARNING

Do not use the AIGX to measure the pressure of explosive or flammable gases or mixtures.

WARNING

During operation, the surface of the ion gauge tube might become hot. To avoid risk of injury, do not touch the tube whilst the gauge is operating. Switch off the gauge and allow to cool down for few minutes before handling.

WARNING

Disconnect the electrical supply cable from the AIGX before you remove the AIGX from the vacuum system. High voltages are generated inside the AIGX.

4.1 Enable and disable the AIGX

CAUTION

The gauge should not be operated at pressures higher than 5×10^{-2} torr (6.6×10^{-2} mbar). Operating the AIGX at high pressures may reduce the lifetime of the filament.

If you are using the AIGX with an AGC, refer to the AGC instruction manual for details of how to enable the AIGX. Alternatively, to enable (switch on) the AIGX, connect pin 7 to pin 2. To disable (switch off) the AIGX, disconnect pin 7 from pin 2.

When the AIGX is enabled, the output signal will remain at 9.0 V whilst the emission current is being stabilised. This will take typically 5 seconds (may be longer at lower pressures). After this time the output signal will indicate pressure. If an error occurs, then the output signal will indicate the error.

4.2 Pressure measurement

If you are using an AIGX with an AGC, the pressure measurement is shown on the AGC display. Otherwise, convert the output signal to pressure using the following equation:

$$P = 10^{(V - 10)} \text{ torr}$$

$$P = 10^{(V - 9.875)} \text{ mbar}$$

$$P = 10^{(V - 7.875)} \text{ Pa}$$

where V is the measured voltage in volts. Refer to Figure 4. This formula is valid for the range 0.7 V to 8.7 V.

4.2.1 Calibration in different gases

The equation given in Section 4.2 is for air or nitrogen only. For other gases, the indicated pressure has to be multiplied by a gas calibration factor (GCF).

The following table list the gas calibration factor for most commonly used gases.

Gas	GCF
Helium	5.7
Argon	0.75
Neon	3.3
Krypton	0.5
Xenon	0.35
Hydrogen	2.4
Oxygen	1
Carbon Monoxide	1.15
Carbon Dioxide	0.7

Table 3 - Gas calibration factors for various gases

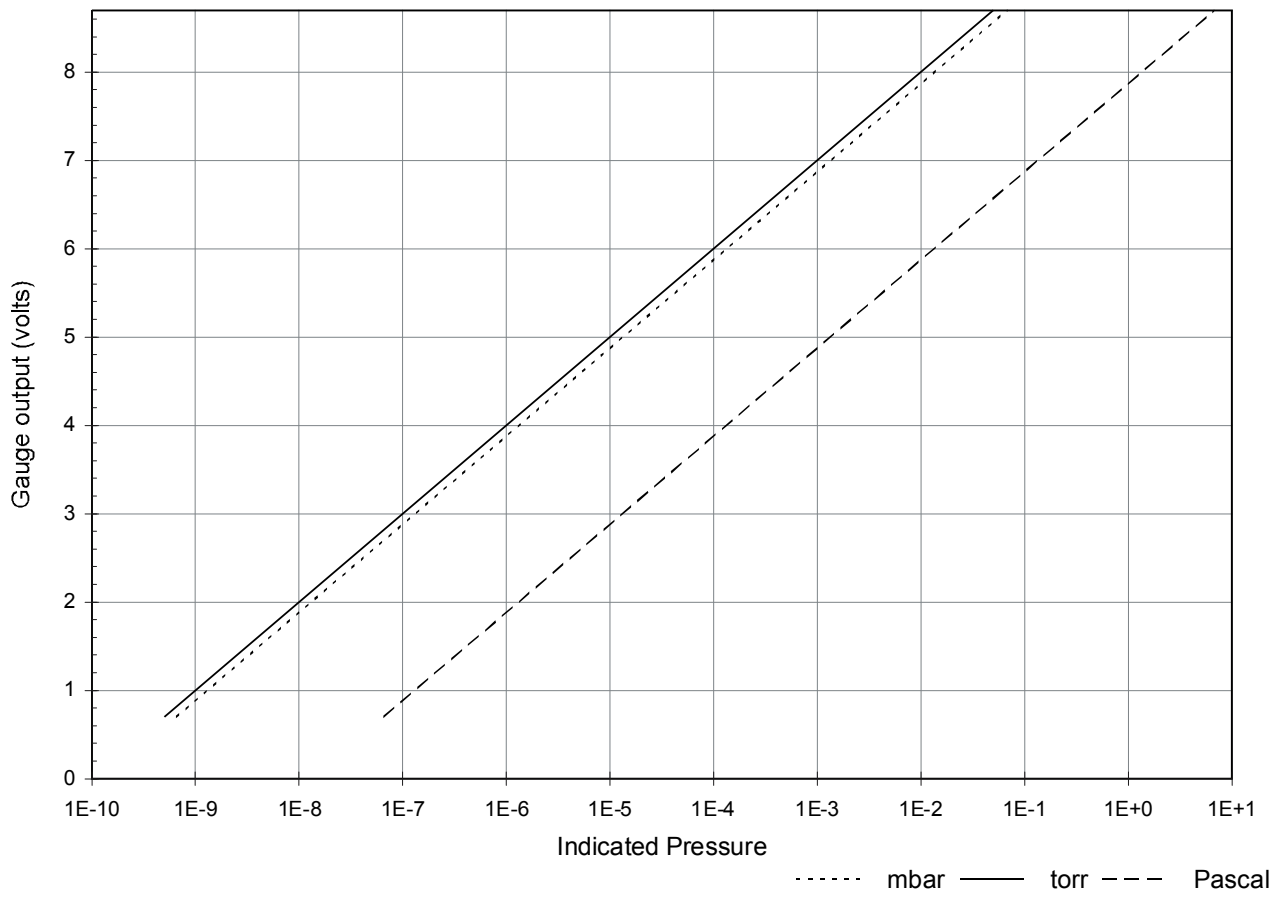

Figure 4 - Pressure output signal of AIGX

4.3 Emission current

To increase the life time of the filament, the two levels of emission currents are automatically controlled by the gauge. As the pressure goes down, the emission current changes from 0.1 mA to 1mA at 2×10^{-5} torr (2.6×10^{-5} mbar). As the pressure goes up, the emission current changes from 1 mA to 0.1 mA at 5×10^{-5} torr (6.6×10^{-5} mbar).

4.4 Degas the AIGX

CAUTION

You must degas the AIGX regularly. Failure to do so will affect the performance and reduce the lifetime of the gauge.

During use in contaminating environments the gauge electrodes become coated in insulating layers, eventually resulting in premature failure of the product. This can be prevented by regular use of the degas feature. Typically, degas will be required on a weekly basis although the interval will depend on the level of contamination.

The degas operation is also recommended if measurement of low pressure are required.

During degas, the grid will be heated to high temperature, sufficient to remove absorbed gases and some contamination.

Degas the AIGX when the pressure is below 1×10^{-5} torr (1.3×10^{-5} mbar). The degas is inhibited when the pressure is above 1×10^{-4} torr (1.3×10^{-4} mbar). The gauge will automatically return to the normal operation mode after 3 minutes.

If you are using the AIGX with an AGC or a TIC controller, refer to the AGC or TIC instruction manual for details of how to degas the AIGX. Otherwise, to enable degassing of the AIGX, connect pin 6 to pin 2.

4.5 Over-pressure protection

The gauge will automatically switch off when the measured pressure rises above 5×10^{-2} torr (6.6×10^{-2} mbar). If this occurs then the signal output and LED status will indicate over-pressure trip. Refer to Section 4.9.

4.6 Filament selection

The AIGX has two filaments, 1 and 2. To select either of these filaments, use the sliding switch at the top of the gauge. Make sure that the gauge is turned off before switching between filaments.

4.7 LED status

The AIGX is fitted with a tri-coloured LED which can be used to monitor the status of the gauge according to the following table:

Colour	Status
Off	No power to the gauge or malfunction
Amber	Power on, gauge disabled
Green/Amber (alternating)	Emissions start-up
Green	Emission on
Green (slow flashing)	Degas on
Red (flashing)	Emission error
Red	Over-pressure trip

Table 4 - LED status

4.8 Set-point adjustment

To read the voltage at which the set-point output signals are activated, press the required set trip switch (refer to Figure 1) with an appropriate tool. The output of the gauge will indicate the set trip level for 3 seconds after which the output will read the normal voltage output.

To adjust the voltage at which the set-point output signal is activated, press the required set trip switch and hold it down for more than 3 seconds. The set-point voltage will start scrolling upwards. Remove pressure from the switch as soon as you reach the required trip voltage. To make a finer adjustment, remove pressure from the set trip switch and immediately depress the switch as many times as required. Each depression will increase the set trip voltage by approximately 10 mV. Refer to Section 4.2 to determine the operating voltage which corresponds to a given pressure.

If required, the set-point signal can be used to indicate when the gauge is operating correctly. Adjust the set-point trip level to > 8.8 V. The set-point output will then be ON when the AIGX is operating normally. The set-point output will be OFF if the gauge is disabled or if an error condition is detected.

4.9 Error indication

If an error occurs during operation of the AIGX, then the output signal and the LED will indicate the error. Refer to Section 5.1 for a fault finding guide.

Error Condition	Output Signal	LED	AGC Display
Emission error	9.5 V	Red flashing	EM ERR
Over-pressure trip	9.7 V	Red	OVER R

Table 5 - Error indication

If an error is indicated then the AIGX will automatically turn off. You should disable the AIGX to remove the error indication, and correct the error. You may then re-enable the AIGX if required.

Note: If you are using the AIGX with an AGC, then the AGC will display an error message and disable the AIGX when an error occurs. In this case the LED status will return to OFF, and you should view the AGC display to determine the error.

4.10 Bakeout

The AIGX tube can be baked to temperatures up to 200 °C after removing the electronics housing. Refer to Figure 5 and the procedure in Section 5.2 to remove and refit the electronics housing.

Ensure that the tube has cooled down before refitting the electronics housing.

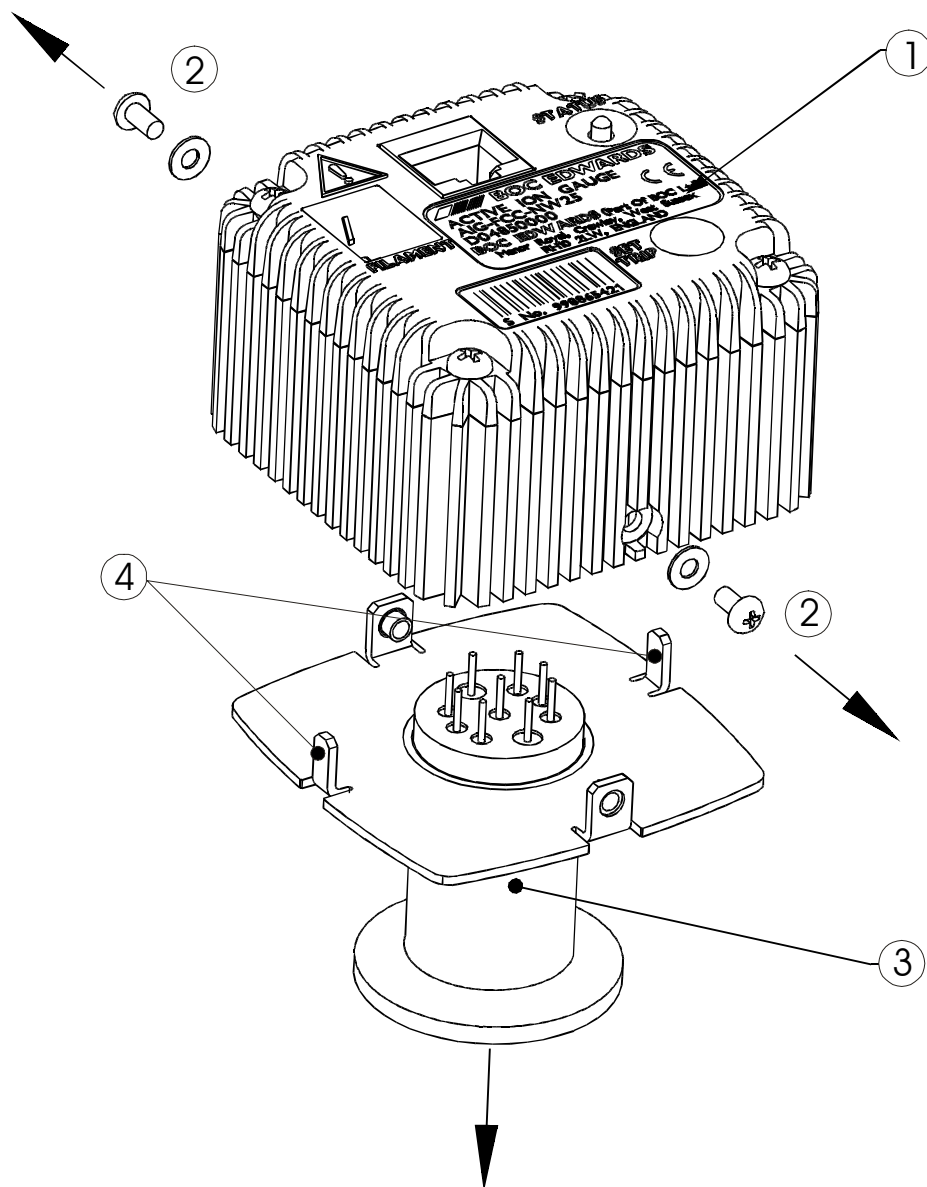

- | | | | |
|----|---------------------|----|--------------------|
| 1. | Electronics housing | 3. | Body tube assembly |
| 2. | Fixing screws | 4. | Locating lugs |

Figure 5 - Separate the electronics housing from the body tube

5 MAINTENANCE

WARNING

Disconnect the electrical supply cable before you start any maintenance. High voltages are generated inside the AIGX.

5.1 Fault finding guide

Symptom	Possible Cause	Remedy
LED Not Lit	Supply connection incorrect or faulty. Supply polarity reversed.	Check electrical supply and connections.
	Internal fuse blown.	Replace fuse. Refer to Section 5.3
Over-pressure trip	The pressure rose too high whilst the AIGX was operating.	Reduce the pressure and re-enable the AIGX.
Emission error	The AIGX was enabled when the pressure was too high.	Reduce the pressure and re-enable the AIGX.
	Filament contaminated. Filament open circuit.	Switch to the other filament. If both filaments give the error, replace the body tube. Refer to Section 5.2.
	Electrical supply insufficient to drive the AIGX.	Check that supply voltage/current specifications meet requirement in Section 2.3.1.

Table 6 - Fault finding guide

5.2 Replace the body tube

Refer to Figure 5 and use the following procedure to replace the body tube.

1. Turn off the gauge.
2. Switch off the AIGX electrical supply and disconnect the electrical supply cable.
3. Remove the AIGX from the vacuum system.
4. Using a suitable screwdriver, remove the two M3 screws (item 2) from the sides of the electronics housing (item 1).
5. Pull the electronics housing (item 1) to remove it from the body tube assembly (item 3).
6. Fit the new body tube assembly (item 3) to the electronics housing (item 1). Take care to ensure that the locating lugs (item 4) on the body tube assembly (item 3) are aligned with the mating recess in the electronics housing (item 1). Note that the electronics housing (item 1) can only fit one way round on the body tube assembly (item 3).
7. Refit the two M3 screws to the sides of the AIGX.

5.3 Replace the internal fuse

If you suspect that the internal fuse has blown, you should check that the voltage and polarity of the electrical supply are correct before replacing the fuse.

To replace the fuse refer to Figure 6 and use the following procedure:

1. Switch off the electrical supply and remove the electrical supply connector from the gauge.
2. Using a suitable screwdriver, remove the four M3.5 screws from the top of the gauge.
3. Remove the gauge lid, ensuring the pin on the underside of the lid is not bent.
4. The fuse will now be visible on the PCB. Hold the board down and then pull the fuse from it's fuseholder using an appropriate tool (for example, a small pair of pliers).

5. The replacement fuse is supplied mounted in a fuseholder. Remove the new fuse from its fuseholder and discard the new fuseholder.
6. Push the new fuse into the fuseholder on the PCB.
7. Refit the gauge lid ensuring that the pin is fitted in the shrouded earth socket next to the main connector. Refit the four M3.5 screws.
8. Apply power to the gauge and check that the LED is illuminated.

Replacement fuses are available from BOC Edwards. Refer to Section 7.2.

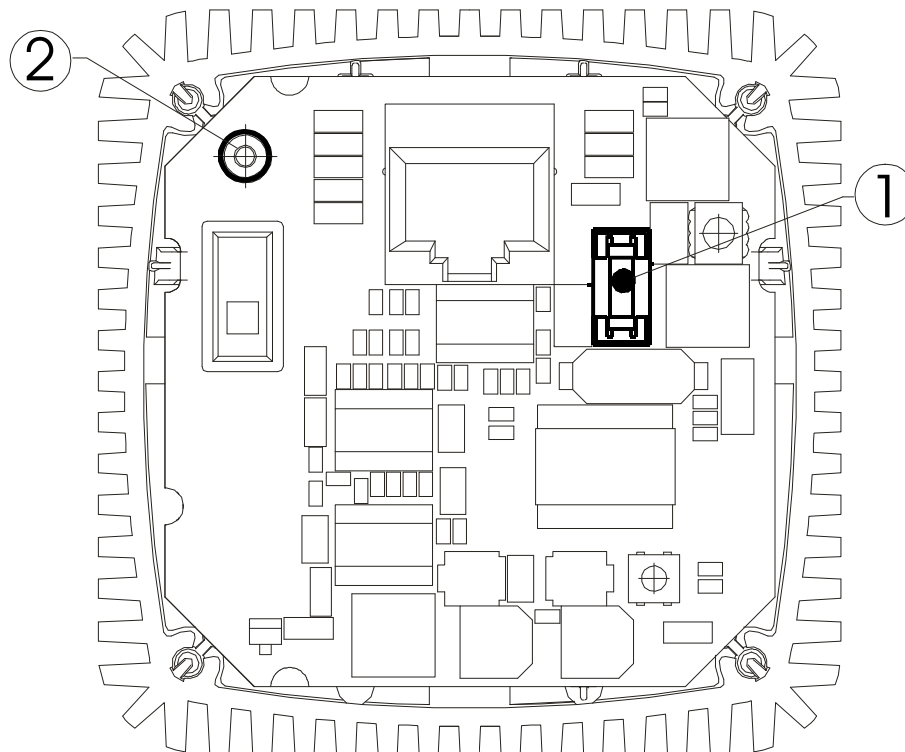

1. Fuse holder

2. Shrouded earth socket

Figure 6 - Fuse replacement

5.4 Calibration service

A calibration service is available for all BOC Edwards gauges. Calibration is by comparison with reference gauges, traceable to National Standards. Contact BOC Edwards for details.

6 STORAGE AND DISPOSAL

6.1 Storage

Return the AIGX to its protective packaging and store the AIGX in clean dry conditions until required for use. Do not exceed the storage temperature conditions specified in Section 2.

When required for use, prepare and install the AIGX as described in Section 3.

6.2 Disposal

Disposal of the AIGX in accordance with all local and national safety and environmental requirements.

Alternatively, you may be able to recycle the AIGX and/or cables; contact BOC Edwards or your supplier for advice (also see below).

The AIGX and associated cables are within the scope of the European Directive on Waste Electrical and Electronic Equipment, 2002/96/EC. From August 2005, BOC Edwards will offer European customers a recycling service for the AIGX/cables at the end of the product's life. Contact BOC Edwards for advice on how to return the AIGX/cables for recycling.

7 SPARES AND ACCESSORIES

7.1 Introduction

BOC Edwards products, spares and accessories are available from BOC Edwards companies in Belgium, Brazil, Canada, France, Germany, Great Britain, Hong Kong, Italy, Japan, Korea, Switzerland, U.S.A, and a world wide network of distributors. The majority of these centres employ Service Engineers who have undergone comprehensive BOC Edwards training courses.

Order spare parts and accessories from your nearest BOC Edwards company or distributor. When ordering, please state for each part required:

- Model and Item Number of your equipment
- Serial number (if any)
- Item Number and description of part

7.2 Spares

Description	Item Number
Electronics housings	
AIGX-S	D048-50-800
Body tubes	
NW25	D048-50-801
DN16CF	D048-51-801
DN40CF	D048-52-801
Spare fuses (pack of 5)	D048-50-805

7.3 Accessories

Cables suitable for use with the AIGX are as follows. These cables are supplied with 8-way male electrical connectors on both ends. Note that the 15 m and 30 m cables have a larger conductor cross-section.

Cable length	Item Number
0.5 m	D400-01-005
1 m	D400-01-010
3 m	D400-01-030
5 m	D400-01-050
10 m	D400-01-100
15 m	D400-05-150
30 m	D400-05-300

Description	Item Number
Annealed copper gasket - DN16CF	C100-01-270
Hex head nut, bolt and washer kit - DN16CF	C100-01-630
Annealed copper gasket - DN40CF	C100-05-270
Hex head nut, bolt and washer kit - DN40CF	C100-05-630

Return of BOC Edwards Equipment - Procedure

INTRODUCTION

Before returning your equipment, you must warn BOC Edwards if substances you used (and produced) in the equipment can be hazardous. This information is fundamental to the safety of our Service Centre employees and will determine the procedures employed to service your equipment.

Complete the Declaration (HS2) and send it to BOC Edwards before you dispatch the equipment. It is important to note that this declaration is for BOC Edwards internal use only, and has no relationship to local, national or international transportation safety or environmental requirements. As the person offering the equipment for shipment, it is your responsibility to ensure compliance with applicable laws.

GUIDELINES

- Equipment is '**uncontaminated**' if it has not been used, or if it has only been used with substances that are not hazardous. Your equipment is '**contaminated**' if it has been used with any substances classified as hazardous under EU Directive 67/548/EEC (as amended) or OSHA Occupational Safety (29 CFR 1910).
- If your equipment has been used with radioactive substances, biological or infectious agents, mercury, polychlorinated biphenyls (PCB's), dioxins or sodium azide, you must decontaminate it before you return it to BOC Edwards. You must send independent proof of decontamination (for example a certificate of analysis) to BOC Edwards with the Declaration (HS2). Phone BOC Edwards for advice.
- If your equipment is contaminated, you must either:
 - Remove all traces of contamination (to the satisfaction of laws governing the transportation of dangerous/hazardous substances).
 - Or, properly classify the hazard, mark, manifest and ship the equipment in accordance with applicable laws governing the shipment of hazardous materials.

Note: Some contaminated equipment may not be suitable for airfreight.

PROCEDURE

1. Contact BOC Edwards and obtain a Return Authorisation Number for your equipment.
2. Complete the Return of BOC Edwards Equipment - Declaration (HS2).
3. If the equipment is contaminated, you must contact your transporter to ensure that you properly classify the hazard, mark, manifest and ship the equipment, in accordance with applicable laws governing the shipment of contaminated/hazardous materials. As the person offering the equipment for shipment, it is your responsibility to ensure compliance with applicable law. **Note: Equipment contaminated with some hazardous materials, such as semiconductor by-products, may not be suitable for airfreight - contact your transporter for advice.**
4. Remove all traces of hazardous gases: pass an inert gas through the equipment and any accessories that will be returned to BOC Edwards. Where possible, drain all fluids and lubricants from the equipment and its accessories.
5. Seal up all of the equipment's inlets and outlets (including those where accessories were attached) with blanking flanges or, for uncontaminated product, with heavy gauge tape.
6. Seal equipment in a thick polythene/polyethylene bag or sheet.
7. If the equipment is large, strap the equipment and its accessories to a wooden pallet. If the equipment is too small to be strapped to a pallet, pack it in a suitable strong box.
8. Fax or post a copy of the Declaration (HS2) to BOC Edwards. The Declaration must arrive before the equipment.
9. Give a copy of the Declaration (HS2) to the transporter. You must tell your transporter if the equipment is contaminated.
10. Seal the original Declaration in a suitable envelope: attach the envelope securely to the outside of the equipment package, in a clear weatherproof bag.

WRITE YOUR RETURN AUTHORISATION NUMBER CLEARLY ON THE OUTSIDE OF THE ENVELOPE OR ON THE OUTSIDE OF THE EQUIPMENT PACKAGE.

Return of BOC Edwards Equipment - Declaration

Return Authorisation Number:

You must:

- Know about all of the substances which have been used and produced in the equipment before you complete this Declaration
- Read the Return of BOC Edwards Equipment - Procedure (HS1) before you complete this Declaration
- Contact BOC Edwards to obtain a Return Authorisation Number and to obtain advice if you have any questions
- Send this form to BOC Edwards before you return your equipment

SECTION 1: EQUIPMENT

Equipment/System Name _____

Part Number _____

Serial Number _____

Has the equipment been used, tested or operated ?

 YES Go to Section 2 NO Go to Section 4

IF APPLICABLE:

Tool Reference Number _____

Process _____

Failure Date _____

Serial Number of Replacement Equipment _____

SECTION 2: SUBSTANCES IN CONTACT WITH THE EQUIPMENT
Are any substances used or produced in the equipment:

- Radioactive, biological or infectious agents, mercury, poly chlorinated biphenyls (PCBs), dioxins or sodium azide? (if YES, see Note 1) YES NO
- Hazardous to human health and safety? YES NO

Note 1 : BOC Edwards will not accept delivery of any equipment that is contaminated with radioactive substances, biological/infectious agents, mercury, PCB's, dioxins or sodium azide, unless you:

- Decontaminate the equipment
- Provide proof of decontamination

YOU MUST CONTACT BOC EDWARDS FOR ADVICE BEFORE YOU RETURN SUCH EQUIPMENT

SECTION 3: LIST OF SUBSTANCES IN CONTACT WITH THE EQUIPMENT

Substance name	Chemical Symbol	Precautions required (for example, use protective gloves, etc.)	Action required after a spill, leak or exposure

SECTION 4: RETURN INFORMATION

Reason for return and symptoms of malfunction _____

- If you have a warranty claim:
- who did you buy the equipment from ? _____
 - give the supplier's invoice number _____

SECTION 5: DECLARATION

Print your name: _____ Print your job title: _____

Print your organisation: _____

Print your address: _____

Telephone number: _____ Date of equipment delivery: _____

I have made reasonable enquiry and I have supplied accurate information in this Declaration. I have not withheld any information, and I have followed the Return of BOC Edwards Equipment - Procedure (HS1).

Note: Please print out this form, sign it and return the signed form as hard copy.

Signed: _____ Date _____

This page intentionally blank.

EUROPE/UNITED KINGDOM**BOC EDWARDS**

Manor Royal
Crawley
West Sussex, RH10 9LW
Tel +(44) 1293 528844
Fax +(44) 1293 533453

AMERICAS**USA HEADQUARTERS****BOC EDWARDS**

One Edwards Park
301 Ballardvale Street
Wilmington, MA 01887
Tel +(1) 978 658 5410
Toll Free (USA only) 1800 848 9800
Fax +(1) 978 658 5410

3901 Burton Drive
Santa Clara, CA 95054
Tel +(1) 408 496 1117
Fax +(1) 408 496 1118

1810 West Drake Drive
Suite 101
Tempe, AZ 85283
Tel +(1) 480 777 7007
Fax +(1) 480 777 2244

4117 Commercial Center Drive
Austin, TX 78744
Tel +(1) 512 416 0102
Fax +(1) 512 328 9846

3501 Island Avenue
Philadelphia, PA 19153
Tel +(1) 215 365 8653
Fax +(1) 978 756 6846

U.S. National Sales Center
Mon 8:30 A. M. - 8:00 P.M. EST
Tues 8:30 A. M. - 8:00 P.M. EST
Wed 8:30 A. M. - 8:00 P.M. EST
Thurs 8:30 A. M. - 8:00 P.M. EST
Fri 8:30 A. M. - 6:30 P.M. EST

BELGIUM**BOC EDWARDS**

Bergensesteenweg 709
B1600 Sint-Pieters-Leeuw
Brussels
Tel +(32) 2 363 0030
Fax +(32) 2 363 0064

BRAZIL**BOC DO BRAZIL LTDA**

Rua Bernado Wrona 222
02710 São Paulo-SP
Brazil
Tel +(55) 11 3952 5000
Fax +(55) 11 3965 2766

CANADA**BOC EDWARDS**

5975 Falbourne Street
Mississauga, Ontario L5R3W6
Canada
Tel +(1) 800 387 4076
Fax +(1) 905 501 1225

12055 Cote de Liesse
Dorval, Quebec H9P1B4
Canada
Tel +(1) 514 631 3501
Fax +(1) 514 631 3502

CHINA**BOC TRADING (SHANGHAI)
CO. LTD**

23 Fu Te Road(N),
Wai Gao Qiao Free Trade Zone
Pudong, Shanghai, 200131,
PRC, China
Tel +(86 21) 58669618
Fax +(86 21) 58669993

GERMANY**BOC EDWARDS**

Ammerthalstraße 36
85551 Kirchheim
Munich
Tel +(49) 89 99 19 18 0
Fax +(49) 89 99 19 18 99

FRANCE**BOC EDWARDS**

125 Avenue Louis Roche
92238 Gennevilliers, Cedex
Paris
Tel +(33) 1 47 98 24 01
Fax +(33) 1 47 98 44 54

HONG KONG S.A.R.**BOC EDWARDS (ASIA)**

12 Chun Yat Street
Tseung Kwan O Industrial
Estate
Tseung Kwan O, Kowloon
Hong Kong SAR
Tel +(852) 2372 2640
Fax +(852) 2796 9095

INDIA**BOC EDWARDS****DIVIN. OF BOC INDIA LIMITED**

203 Surya Kiran Building
19 Kasturba Gandhi Marg
New Delhi - 110 001
India
Tel +(91) 11 237 33087
Fax +(91) 11 551 0245

ISRAEL**EDWARDS ISRAEL VACUUM LTD**

5 Habarzel Blvd
Gat 2000 Industrial Zone
Qiryat Gat 82000
Tel +(972) 8 681 0633
Fax +(972) 8 681 0640

ITALY**BOC EDWARDS**

Via Carpaccio 35
20090 Trezzano sul Naviglio
Milan
Tel +(39) 2 48 4471
Fax +(39) 2 48 401638

JAPAN**HEADQUARTERS****BOC EDWARDS**

Shwa Shiba Park Building A-3F
2-4-1 Shibakoen Minato-ku
Tokyo, 105-0011
Tel +(81)(0) 3 5470 6530
Fax +(81)(0) 3 5470 6521

KOREA**HEADQUARTERS****SONGWON EDWARDS LTD**

5th FL. Daewoo Engineering
Bldg.
Soonae-dong
Bundang-gu, Sungnam City
Kyungki-do, Korea
Tel +(82) 31 716 7070
Fax +(82) 31738 1001

SONGWON EDWARDS LTD

625-7 Upsong-dong
Chunan City
Chungchong Nam-do
Korea
Tel +(82) 41 621 7070
Fax +(82) 41 621 7700

SINGAPORE**BOC EDWARDS (ASIA)**

42 Loyang Drive
Loyang Industrial Estate
Singapore 508962
Tel +(65) 546 8408
Fax +(65) 546 8407

TAIWAN, R.O.C.**EDWARDS TAIWAN LIMITED**

No. 434 Chung-hua Road
Toufen Town, Miaoli County
Taiwan R.O.C.
Tel +(886) 37 611422
Fax +(886) 37 611401

PLEASE CONTACT ANY OF THE ABOVE FOR DETAILS OF OTHER SALES AND SERVICE CENTERS IN YOUR AREA.

BOC Edwards is part of BOC Limited. BOC Edwards and the stripe symbol are trade marks of The BOC Group
© BOC Edwards 2004
Publication No. C100-04-895

www.bocedwards.com
info@bocedwards.com

